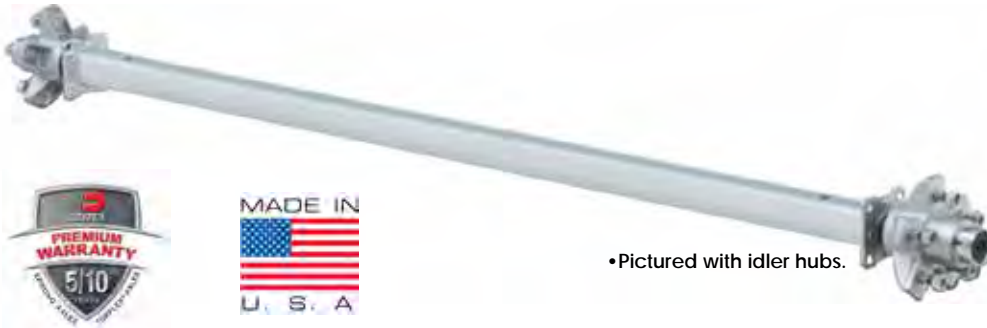

TABLE OF CONTENTS

PRODUCT	PAGE
Marine Trailer Quick Reference Buying Guide	1
Axles	2
Brakes	5
Disc Brakes	6
Hubs - Hubs & Drums	10
Bearing Buddy	12
Suspension	15
Bolster Brackets	17
Guide-Ons & Brackets	18
Roller & Bunk Brackets	19
Carpeting	20
Winches & Winch Stands / Posts	21
Galvanize Spray Paint	21
PVC Tube Caps	21
Winches	22
Fender & Fender Brackets	23
Bunk Wraps & Slides	25
Rollers, Keel Pads & Bow Guards	26
Tire & Wheels	28
Tire & Wheel Accessories	33
Spare Tire Mounts	34
Jacks	36
Couplers	37
Pintles & Ball Mounts	40
Receiver Tubes	42
Hitch Balls	44
Weight Distribution & Sway Control Hitch	44
Transom Tie Downs & Safety Chains	46
Tongue Boxes & Chemicals	47
Locks	48
Lights	51
Conspicuity Tape	52
Electrical	60
Batteries, Battery Chargers & Solar Panels	62
NOCO	62
Breakaway Kits	63
Brake Controls	64
Actuators	65
Actuator Parts	71
Electric Over Hydraulic Units	89
Brake Lines	92



MARINE TRAILER QUICK REFERENCE BUYING GUIDE



•Pictured with idler hubs.



•Axle Beam Mounting U-Bolt Kit



•Axle Beam Sliding Saddle



M22 Square Tube Spring Axle Beam

STANDARD FEATURES:

- *EZ-Lube Spindles Standard on Axles & Beams
- *Stainless Steel Wear Sleeves
- *Hot Dip Galvanized Beam
- *Gal-Dex Coated Hubs & Hub/Drum
- *1 1/16" Spindle with 2" x .180 Square Tube
- *L44649 Inner & Outer Bearing
- *Non-Cambered Axle Beam

HUB FACE	TIP-TO-TIP	ITEM NO
47"	52"	6100894
49"	54"	6100938
51"	56"	6100931
53"	58"	6100939
55"	60"	6100940
57"	62"	6100941
59"	64"	6100942
61"	66"	6100943
63"	68"	6100965
65"	70"	6100966
67"	72"	6100967
69"	74"	6100972
71"	76"	6100673
73"	78"	6100968
75"	80"	6100969
77"	82"	6100970
79"	84"	6100971

M35 Square Tube Spring Axle Beam

STANDARD FEATURES:

- *EZ-Lube Spindles Standard on Axles & Beams
- *Stainless Steel Wear Sleeves
- *Hot Dip Galvanized Beam
- *Gal-Dex Coated Hubs & Hub/Drum
- *84F Spindle with 2" x .250 Square Tube
- *L68149 Inner Bearing & L44649 Outer Bearing
- *Non-Cambered Axle Beam

HUB FACE	TIP-TO-TIP	ITEM NO
65"	70"	6100895
67"	72"	6100963
69"	74"	6100964
71"	76"	6100946
73"	78"	6100948
75"	80"	6100949
77"	82"	6100951
79"	84"	6100961
81"	86"	6100962
83"	88"	6100932
85"	90"	6100933
87"	92"	6100934
89"	94"	6100935
91"	96"	6100936
93"	98"	6100945
95"	100"	6100944
97"	102"	6100937

QUICK ORDER ITEM NUMBERS

REF NO	ITEM NO	DESCRIPTION
1	9100270	2" GALVANIZED SQUARE U-BOLT KIT
2	9000573	2" GALVANIZED SLIDING SADDLES
	9850237	2"X4" WINCH STAND KIT
	9850236	3"X4" WINCH STAND KIT

Note: Bow Stop Center Bolt, Winch, nor Cap Included with Winch Stand Kits



•Winch Stand Assy.
Shown for illustration only.

POPULAR LIGHT KITS

REF NO	ITEM NO	DESCRIPTION
3	8100565-02	UNDER 80" STUD MOUNT COMPLETE WATERPROOF STOP, TURN & TAIL TRAILER LIGHT KIT
4	8100565-03	UNDER 80" STUD MOUNT COMPLETE WATERPROOF STOP, TURN & TAIL TRAILER LIGHT KIT WITH CLEARANCE MARKER LIGHTS

MARINE TRAILER QUICK REFERENCE BUYING GUIDE

AXLES =

There are several axle options for Marine trailers. Below is a summary of the axles offered. For complete axle specifications, details and features see the 2017 TexTrail Trailer Parts Catalog or ask your sales representative for information not included in this catalog.



M22 Square Tube Spring Axle

STANDARD FEATURES:

- *2.2K Capacity Axle Beam
- *EZ-Lube Spindles
- *Stainless Steel Wear Sleeves
- *Hot Dip Galvanized Beam
- *Gal-Dex Coated Hubs
- *1 1/16" Spindle with 2" x .180" Square Tube
- *L44649 Inner & Outer Bearing
- *Non-Cambered Axle Beam

UPGRADE OPTIONS:

- *V-Bent Center Beam



M35 Square Tube Spring Axle

STANDARD FEATURES:

- *3.5K Capacity Axle Beam
- *EZ-Lube Spindles
- *Stainless Steel Wear Sleeves
- *Hot Dip Galvanized Beam
- *Gal-Dex Coated Hubs & Hub/Drum
- *84F Spindle with 2" x 0.250" Square Tube Beam
- *L68149 Inner Bearing & L44649 Outer Bearing
- *Non-Cambered Axle Beam

UPGRADE OPTIONS:

- *V-Bent Center Beam
- *Hydraulic Freebacking or Disc Brakes



D22 Round Tube Spring Axle

STANDARD FEATURES:

- *2.2K Capacity Axle Beam
- *EZ-Lube Spindles
- *Stainless Steel Wear Sleeves
- *Hot Dip Galvanized Beam
- *Gal-Dex Coated Hubs
- *1 1/16" Spindle with 1.75" x 0.156" Round Tube Beam
- *L44649 Inner & Outer Bearing
- *Non-Cambered Axle Beam

UPGRADE OPTIONS:

- *V-Bent Center Beam



Brake axle shown for illustration only.

D35 Round Tube Spring Axle

STANDARD FEATURES:

- *3.5K Capacity Axle Beam
- *EZ-Lube Spindles
- *Stainless Steel Wear Sleeves
- *Hot Dip Galvanized Beam
- *Gal-Dex Coated Hubs & Hub/Drum
- *84F Spindle with 2.38" x 0.156" Round Tube Beam
- *L68149 Inner Bearing & L44649 Outer Bearing
- *Non-Cambered Axle Beam

UPGRADE OPTIONS:

- *V-Bent Center Beam
- *Drop Spindle with 3" x 0.191" Round Tube Beam
- *Hydraulic Freebacking or Disc Brakes



9 Torsion Suspension Axle

STANDARD FEATURES:

- *2.2K Capacity Axle Beam
- *EZ-Lube Spindles
- *Stainless Steel Wear Sleeves
- *Hot Dip Galvanized Beam
- *GAL-DEX™ Coated Hubs & Hub/Drum
- *1-1/16" Spindle with 2.17" Square Tube Beam
- *L44649 Inner & Outer Bearing
- *Cambered Axle Beam

UPGRADE OPTIONS:

- *V-Bent Center Beam
- *Removable Spindles



10 Torsion Suspension Axle

STANDARD FEATURES:

- *3.5K Capacity Axle Beam
- *EZ-Lube Spindles
- *Stainless Steel Wear Sleeves
- *Hot Dip Galvanized Beam
- *GAL-DEX™ Coated Hubs & Hub/Drum
- *84F Spindle with 2.62" Square Tube Beam
- *L68149 Inner Bearing & L44649 Outer Bearing
- *Cambered Axle Beam

UPGRADE OPTIONS:

- *V-Bent Center Beam
- *Removable Spindles
- *Hydraulic Freebacking or Disc Brakes



AXLES =



D52 Round Tube Spring Axle

STANDARD FEATURES:

- *5.2K Capacity Axle Beam
- *EZ-Lube Spindles
- *Stainless Steel Wear Sleeves
- *Hot Dip Galvanized Beam
- *GAL-DEX™ Coated Hubs & Hub/Drum
- *42F Spindle with 3" x 0.191" Round Tube Beam
- *25580 Inner Bearing & LM67048 Outer Bearing
- *Non-Cambered Axle Beam

UPGRADE OPTIONS:

- *V-Bent Center Beam
- *Drop Spindle with 3" x 0.250" Round Tube Beam
- *Hydraulic Freebacking or Disc Brakes



Brake axle shown for illustration only.

D60 Round Tube Spring Axle

STANDARD FEATURES:

- *6K Capacity Axle Beam
- *EZ-Lube Spindles
- *Stainless Steel Wear Sleeves
- *Hot Dip Galvanized Beam
- *GAL-DEX™ Coated Hubs & Hub/Drum
- *42F Spindle with 3" x 0.250" Round Tube Beam
- *655 Bolt - 25580 Inner Bearing & 15123 Outer Bearing
- *865 Bolt - 25580 Inner Bearing & 14125A Outer Bearing
- *Non-Cambered Axle Beam

UPGRADE OPTIONS:

- *V-Bent Center Beam
- *Drop Spindle with 3" x 0.302" Round Tube Beam
- *Hydraulic Freebacking or Disc Brakes



11 Torsion Suspension Axle

STANDARD FEATURES:

- *5.2K Capacity Axle Beam
- *EZ-Lube Spindles
- *Stainless Steel Wear Sleeves
- *Hot Dip Galvanized Beam
- *GAL-DEX™ Coated Hubs & Hub/Drum
- *42F Spindle with 3.03" Square Tube Beam
- *25580 Inner Bearing & LM67048 Outer Bearing
- *Cambered Axle Beam

UPGRADE OPTIONS:

- *V-Bent Center Beam
- *Removable Spindles
- *Hydraulic Freebacking or Disc Brakes



11 Torsion Suspension Axle

STANDARD FEATURES:

- *6K Capacity Axle Beam
- *EZ-Lube Spindles
- *Stainless Steel Wear Sleeves
- *Hot Dip Galvanized Beam
- *GAL-DEX™ Coated Hubs & Hub/Drum
- *42F Spindle with 3.03" Square Tube Beam
- *655 Bolt - 25580 Inner Bearing & 15123 Outer Bearing
- *865 Bolt - 25580 Inner Bearing & 14125A Outer Bearing
- *Cambered Axle Beam

UPGRADE OPTIONS:

- *V-Bent Center Beam
- *Removable Spindles
- *Hydraulic Freebacking or Disc Brakes



Brake axle shown for illustration only.

D70 Round Tube Spring Axle

STANDARD FEATURES:

- *7K Capacity Axle Beam
- *EZ-Lube Spindles
- *Stainless Steel Wear Sleeves
- *Hot Dip Galvanized Beam
- *GAL-DEX™ Coated Hubs & Hub/Drum
- *42F Spindle with 3" x 0.250" Round Tube Beam
- *25580 Inner Bearing & 14125A Outer Bearing
- *Cambered Axle Beam

UPGRADE OPTIONS:

- *V-Bent Center Beam
- *Drop Spindle with 3.50" x 0.250" Round Tube Beam
- *Hydraulic Freebacking or Disc Brakes



Brake axle shown for illustration only.

12 Torsion Suspension Axle

STANDARD FEATURES:

- *7K Capacity Axle Beam
- *EZ-Lube Spindles
- *Stainless Steel Wear Sleeves
- *Hot Dip Galvanized Beam
- *GAL-DEX™ Coated Hubs & Hub/Drum
- *42F Spindle with 3.50" Square Tube Beam
- *25580 Inner Bearing & 14125A Outer Bearing
- *Cambered Axle Beam

UPGRADE OPTIONS:

- *V-Bent Center Beam
- *Removable Spindles
- *Hydraulic Freebacking or Disc Brakes

REMOVABLE SPINDLES =

"Ability to replace a damaged spindle in the field greatly reduces repair costs by not having to replace the complete axle."*



REPLACEMENT SPINDLE KIT		
DESCRIPTION	ID NO.	ITEM NO.
TF#9 2.2K REMOVABLE SPINDLE KIT	K71-742-00	8750108
TF#10 3.5K REMOVABLE SPINDLE KIT	K71-743-00	8750109
TF#11 6K REMOVABLE SPINDLE KIT	K71-744-00	8750110
TF#12 7K REMOVABLE SPINDLE KIT	K71-745-00	8750111

REMOVABLE SPINDLES

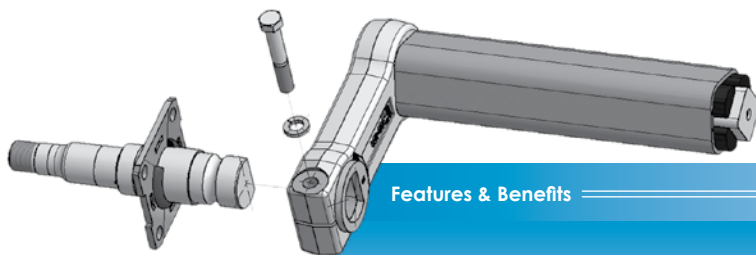

Features & Benefits

- Ability to replace a damaged spindle in the field greatly reduces repair costs by not having to replace the complete axle.
- With only one bolt to remove, the procedure is quick and easy
- Removal of the spindle requires no special tools.
- A positive spindle location with "D" washer design ensures proper brake flange location for brakes and EZ-Lube® hole.
- Positive depth location with clamping bolt and detent groove takes out the guess work with no measuring required.
- Clamping bolt and washer are made of stainless steel to resist corrosion resulting in easy removal.
- One spindle will replace either side, no need to order a left hand and right hand side.

Ordering Information:

- Removable Spindle Option must be designated at the time of ordering the axle.
- Only replace hub or hub-drum if damaged, although the bearing cones, cups and seals should be replaced.

*Only available on axles originally ordered from factory with specifically designed arms.



HYDRAULIC DRUM BRAKES =



Demco Freebacking Brakes incorporate a "Fall-Away" shoe which diminishes shoe drag when backing. The galvanized backing plate, stainless steel spring hardware, plated wheel cylinder and riveted marine brake shoe make this brake assembly highly durable. Requires periodic manual adjustment.



- Demco Marine Brake has galvanized back plate, stainless steel spring hardware, plated wheel cylinder and riveted marine brake shoe.
- 4 on 4.00" Bolt Hole Pattern
- 13" - 15" Wheel Size

3,500 LBS. • 10" X 2 1/4" HYDRAULIC FREEBACKING MARINE BRAKE ASSEMBLY		
ITEM NO.	ID NO.	DESCRIPTION
6400028	SB40716M	LH COMPLETE BRAKE ASSEMBLY
6400029	SB40715M	RH COMPLETE BRAKE ASSEMBLY
6450394	SB9777M	LH WHEEL CYLINDER ASSEMBLY
6450393	SB9776M	RH WHEEL CYLINDER ASSEMBLY



- Demco Marine Brake has galvanized back plate, stainless steel spring hardware, plated wheel cylinder and riveted marine brake shoe.
- 5 on 3.875" Bolt Hole Pattern
- 14.5" - 16" Wheel Size

7,000 LBS. • 12" X 2" HYDRAULIC FREEBACKING MARINE BRAKE ASSEMBLY		
ITEM NO.	ID NO.	DESCRIPTION
6400086	SB42029M	LH COMPLETE BRAKE ASSEMBLY
6400085	SB42028M	RH COMPLETE BRAKE ASSEMBLY
6450394	SB9777M	LH WHEEL CYLINDER ASSEMBLY
6450393	SB9776M	RH WHEEL CYLINDER ASSEMBLY

HYDRAULIC DISC BRAKES • 1-AXLE KITS



Experience the Deemaxx Difference:

- Exclusive MAXX COATING on caliper passed Salt Spray Test per ASTM-B-117-09 over 1008 hours with no RUST!
- Exclusive 120° Bleeder design means better bleeding, balanced system, and no more damaged bleeders!
- Exclusive Laser writing on caliper means instructions are always there!
- Exclusive Bolt design means no more mishandling or incorrect shipping of bolts!
- Exclusive Reverse Mount Slip On Rotor means cooler running, better plating, and no more premature corrosion!
- LIMITED LIFETIME WARRANTY!
- Ceramic Brake Pads are slotted, chamfered, and have a Stainless Steel Clip!
- Equals better stopping, longer life and corrosion protection!
- Solid / Rigid Ductile Iron Casting eliminate flexing and give you more Brake Torque!
- Bracket design give you twice as many mounting options for your caliper position!
- Uses only ISO QUALITY Certified Factories!
- PASSED THE SAE J2681 BRAKE TEST!



•The Best Salt Water Brake Available!



Available in MAXX COATING or STAINLESS STEEL 3,500 lbs. to 10,000 lbs. General Duty. Available as a Slip-On or Integral Kit.



•Slip-On



•Integral

This unique rotor cross section design actively draws cooling air from the rotor interior.



3.5K - 10K HEAVY DUTY HYDRAULIC DISC BRAKES • DEEMAXX COMPONENTS DISC BRAKE KIT • COMPLETE FOR ONE AXLE

ITEM NO.	ID NO.	CAPACITY	SIZE	SIZE	DESCRIPTION
6450510	DBI-3.5K-MAXX	3.5K	10"	1/2"	INTEGRAL DISC BRAKE KIT MAXX
6450511	DBI-3.5K-MAXX-SS	3.5K	10"	1/2"	INTEGRAL DISC BRAKE KIT MAXX - SS CALIPER
6450503	DBSO-3.5K-MAXX	3.5K	10"	1/2"	SLIP-ON DISC BRAKE KIT MAXX
6450504	DBSO-3.5K-MAXX-SS	3.5K	10"	1/2"	SLIP-ON DISC BRAKE KIT MAXX - SS CALIPER
6450505	DBSO-3.5K-SS	3.5K	10"	1/2"	SLIP-ON DISC BRAKE KIT ALL STAINLESS STEEL
6450586	DBI-6K-MAXX	5.2-6K	12"	1/2"	INTEGRAL DISC BRAKE KIT MAXX
6450587	DBI-6K-MAXX-SS	5.2-6K	12"	1/2"	INTEGRAL DISC BRAKE KIT MAXX - SS CALIPER
6450579	DBSO-6K-MAXX	5.2-6K	12"	1/2"	SLIP-ON DISC BRAKE KIT MAXX
6450580	DBSO-6K-MAXX-SS	5.2-6K	12"	1/2"	SLIP-ON DISC BRAKE KIT MAXX - SS CALIPER
6450581	DBSO-6K-SS	5.2-6K	12"	1/2"	SLIP-ON DISC BRAKE KIT ALL STAINLESS STEEL
6450676	DBI-7K-MAXX	7K	13"	1/2"	INTEGRAL DISC BRAKE KIT MAXX
6450677	DBI-7K-MAXX-SS	7K	13"	1/2"	INTEGRAL DISC BRAKE KIT MAXX - SS CALIPER
6450681	DBI-7K9-MAXX	7K	13"	9/16"	INTEGRAL DISC BRAKE KIT MAXX
6450682	DBI-7K9-MAXX-SS	7K	13"	9/16"	INTEGRAL DISC BRAKE KIT MAXX - SS CALIPER
6450690	DBI-7K10-MAXX	7K	13"	5/8"	INTEGRAL DISC BRAKE KIT MAXX
6450415	DBI-7K10-MAXX-SS	7K	13"	5/8"	INTEGRAL DISC BRAKE KIT MAXX - SS CALIPER
6450657	DBSO-7K-MAXX	7K	13"	1/2"	SLIP-ON DISC BRAKE KIT MAXX
6450658	DBSO-7K-MAXX-SS	7K	13"	1/2"	SLIP-ON DISC BRAKE KIT MAXX - SS CALIPER
6450659	DBSO-7K-SS	7K	13"	1/2"	SLIP-ON DISC BRAKE KIT ALL STAINLESS STEEL
6450663	DBSO-7K9-MAXX	7K	13"	9/16"	SLIP-ON DISC BRAKE KIT MAXX
6450662	DBSO-7K9-MAXX-SS	7K	13"	9/16"	SLIP-ON DISC BRAKE KIT MAXX - SS CALIPER
6450669	DBSO-7K10-MAXX	7K	13"	5/8"	SLIP-ON DISC BRAKE KIT MAXX
6450670	DBSO-7K10-MAXX-SS	7K	13"	5/8"	SLIP-ON DISC BRAKE KIT MAXX - SS CALIPER
6450760	DBI-8KD9-MAXX	8K	13"	9/16"	INTEGRAL DISC BRAKE KIT MAXX
6450765	DBI-8KD10-MAXX	8K	13"	5/8"	INTEGRAL DISC BRAKE KIT MAXX
6450745	DBSO-8KD9-MAXX	8K	13"	9/16"	SLIP-ON DISC BRAKE KIT MAXX
6450747	DBSO-8KD9-MAXX-SS	8K	13"	9/16"	SLIP-ON DISC BRAKE KIT MAXX - SS CALIPER
6450748	DBSO-8KD9-SS	8K	13"	9/16"	SLIP-ON DISC BRAKE KIT ALL STAINLESS STEEL
6450752	DBSO-8KD10-MAXX	8K	13"	5/8"	SLIP-ON DISC BRAKE KIT MAXX
6450753	DBSO-8KD10-MAXX-SS	8K	13"	5/8"	SLIP-ON DISC BRAKE KIT MAXX - SS CALIPER
6450755	DBSO-8KD10-SS	8K	13"	5/8"	SLIP-ON DISC BRAKE KIT ALL STAINLESS STEEL
6450414*	DBSI-10K-MAXX	9K-10KGD	13"	5/8"	INTEGRAL DISC BRAKE KIT MAXX

* Designed Specifically to work on 17.5" Dual Tandem applications only.

REPLACEMENT DISC BRAKE PAD KITS

ITEM NO.	DESCRIPTION	CAPACITY	MATERIAL
6450392	DISC PAD KIT 1-AXLE	3.5K - 6K	STAINLESS STEEL
6450620	DISC PAD KIT 1-AXLE	3.5K - 6K	CERAMIC
6450810	DISC PAD KIT 1-AXLE	7K - 8K	CERAMIC
6450406	DISC PAD KIT 1-AXLE	7K - 8K	SEMI-METALLIC



•6450620

Replacement Parts for the Deemaxx Disc Brakes are available. Component Breakdown Schematics can be found in the main TexTrail Parts Catalog starting on page B45.

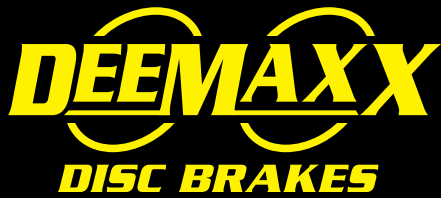

BRAKING ALL THE STANDARDS

Available in MAXX COATING or STAINLESS STEEL 3,500lb to 10,000lb Slip Over or Integral.

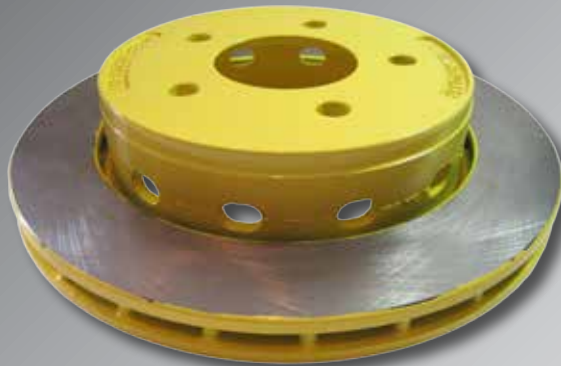

This unique rotor cross section design actively draws cooling air from the rotor interior.

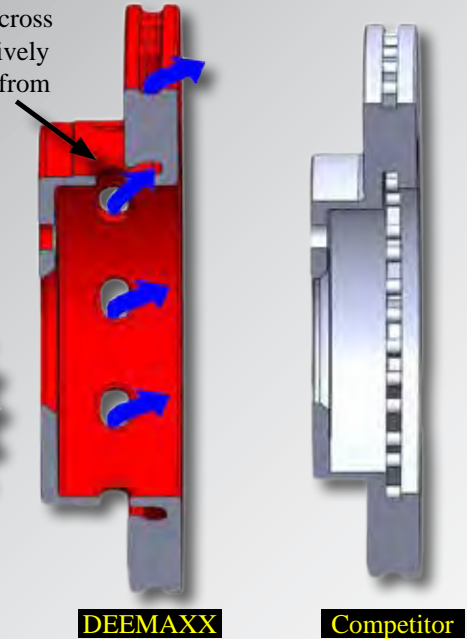

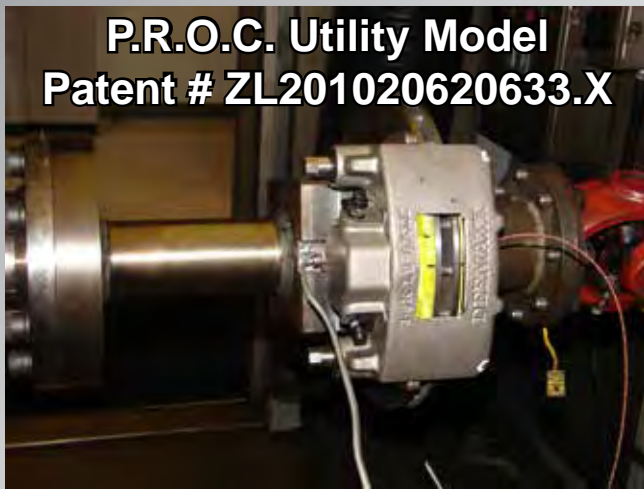

Warranty:
6yr Stainless Steel
3yr MAXX COATING
and
**LIMITED LIFETIME
BRAKE PADS**

DEEMAXX PASSED THE
SAE J2681 BRAKE TEST!



DEEMAXX BENEFITS:

- * **DEEMAXX Exclusive** MAXX COATING on Caliper passed Salt Spray Test per ASTM-B-117-09 over 1008 hrs with no RUST!
- * **DEEMAXX Exclusive** 120° Bleeder design means better bleeding, balanced system, and no more damaged bleeders!
- * **DEEMAXX Exclusive** Laser writing on caliper means instructions are always there!
- * **DEEMAXX Exclusive** Bolt design means no more mishandling or incorrect shipping of bolts!
- * **DEEMAXX Exclusive** Reverse Mount Slip Over Rotor means cooler running, better plating, and no more premature corrosion!
- * **DEEMAXX LIMITED LIFETIME WARRANTY** Ceramic Brake Pads are slotted, chamfered, and have a Stainless Steel Clip.
- * **DEEMAXX** Equals better stopping, longer life and corrosion protection.
- * **DEEMAXX** Solid/Rigid Ductile Iron Casting eliminates flexing and gives you more Brake Torque!
- * **DEEMAXX** Bracket design gives you twice as many mounting options for your caliper position!
- * **DEEMAXX** Uses only ISO QUALITY Certified Factories! 
- * **DEEMAXX PASSED THE SAE J2681 BRAKE TEST!** 

HYDRAULIC DISC BRAKES • 1-WHEEL KITS •



UPF Corrosion Resistance Integral Hub/Rotor & Caliper Disc Brake Kits:

- Corrosion resistant components included in all kits.
- Slider pins, pad guides, and anti-rattle springs are stainless steel in all kits.
- Banjo bolts and bleeder screws are zinc plated on zinc caliper; stainless steel on all other calipers.
- Ventilated rotors for temperature regulation to reduce brake bad deterioration, excessive wear and warping.
- Non-metallic, non-asbestos, organic pad materials to eliminate corrosion.
- Disc brake caliper to be used with 13" and larger wheels.
- Inlet/outlet port positions decrease amount of air in the system through a large range of torsion arm trailing angles.
- Braking forces are transferred to the yoke / anchor and not the caliper slider pins.



Available in ZINC PLATED, ALUMINUM or STAINLESS STEEL.



One Caliper fits either side. Fittings are shipped loose allowing installer to use the caliper on either side.



• Slip-On Kit



• Integral Kit

3.7K - 8K HEAVY DUTY HYDRAULIC DISC BRAKES • UFP BY DEXTER DISC BRAKE KIT • COMPLETE FOR ONE WHEEL

ITEM NO.	ID NO.	CAPACITY	SIZE	SIZE	DESCRIPTION
6450614	K71-077-05	3.7K	10"	1/2"	INTEGRAL DISC BRAKE KIT ZINC PLATED
	K71-078-05	3.7K	10"	1/2"	INTEGRAL DISC BRAKE KIT ZINC - ALUM CALIPER
	K71-079-05	3.7K	10"	1/2"	INTEGRAL DISC BRAKE KIT SS ROTOR - ALUM CALIPER
	K71-088-05	3.7K	10"	1/2"	INTEGRAL DISC BRAKE KIT ALL STAINLESS STEEL
6450719	K71-809-00	3.7K	10"	1/2"	SLIP-ON DISC BRAKE KIT ZINC PLATED
	K71-810-00	3.7K	10"	1/2"	SLIP-ON DISC BRAKE KIT ZINC - ALUM CALIPER
	K71-811-00	3.7K	10"	1/2"	SLIP-ON DISC BRAKE KIT SS ROTOR - ALUM CALIPER
	K71-812-00	3.7K	10"	1/2"	SLIP-ON DISC BRAKE KIT ALL STAINLESS STEEL
6450592	K71-089-05	6K	12"	1/2"	INTEGRAL DISC BRAKE KIT ZINC PLATED
	K71-090-05	6K	12"	1/2"	INTEGRAL DISC BRAKE KIT ZINC - ALUM CALIPER
	K71-954-05	6K	12"	1/2"	INTEGRAL DISC BRAKE KIT SS ROTOR - ALUM CALIPER
	K71-786-05	6K	12"	1/2"	INTEGRAL DISC BRAKE KIT ALL STAINLESS STEEL
	K71-813-00	6K	12"	1/2"	SLIP-ON DISC BRAKE KIT ZINC PLATED
	K71-814-00	6K	12"	1/2"	SLIP-ON DISC BRAKE KIT ZINC - ALUM CALIPER
	K71-815-00	6K	12"	1/2"	SLIP-ON DISC BRAKE KIT SS ROTOR - ALUM CALIPER
	K71-816-00	6K	12"	1/2"	SLIP-ON DISC BRAKE KIT ALL STAINLESS STEEL
	K71-824-05	7K	13"	1/2"	INTEGRAL DISC BRAKE KIT ZINC PLATED
	K71-806-05	7K	13"	1/2"	INTEGRAL DISC BRAKE KIT ZINC - ALUM CALIPER
	K71-807-05	7K	13"	1/2"	INTEGRAL DISC BRAKE KIT SS ROTOR - ALUM CALIPER
	K71-808-05	7K	13"	1/2"	INTEGRAL DISC BRAKE KIT ALL STAINLESS STEEL
K71-820-05	8K	13"	1/2"	INTEGRAL DISC BRAKE KIT ZINC - ALUM CALIPER	

REPLACEMENT DISC BRAKE PAD KITS

ITEM NO.	DESCRIPTION	CAPACITY	MATERIAL
6450563	DISC PAD KIT 1-WHEEL	3.5K - 6K	STAINLESS STEEL



HYDRAULIC DISC BRAKES • 1-WHEEL KITS

FEATURES ON ALL CALIPERS:

- Inlet/outlet design port locations allow better bleeding results.
- Caliper body & piston are made of the same material, allowing the caliper body and piston to have the same rate of thermal expansion. Clearance between piston and caliper body stays the same regardless of temperature change.
- All braking forces are transferred directly to the caliper mounting bracket and not through the slider pins. Removing the braking forces from the slider pins allow the caliper body to float easier, resulting in cooler/better braking and even brake pad wear.
- Calipers can be plumbed in series to reduce the amount of fitting/connection points and ease of bleeding through only one caliper.
- The brass banjo fittings are rotatable which allows the brake lines direct entry into the caliper body from any angle.
- Stainless steel anti-rattle springs for quiet trailering and braking.



Zinc Caliper:

- Zinc Plated Caliper Body
- Chrome Plated Piston
- Zinc Plated Banjo Bolt & Bleeder Screw
- Stainless Steel Slider Pins
- Stainless Steel Pad Guides
- Zinc Plated Back Plate for Brake Pads



Aluminum Caliper:

- Corrosion Resistant Caliper Bracket
- Aluminum Caliper Body
- Aluminum Piston
- Stainless Steel Banjo Bolt & Bleeder Screw
- Stainless Steel Slider Pins
- Stainless Steel Pad Guides
- Corrosion Resistant Back Plate for Brake Pads



Stainless Steel Caliper:

- Stainless Steel Caliper Bracket
- Stainless Steel Caliper Body
- Stainless Steel Piston
- Stainless Steel Banjo Bolt & Bleeder Screw
- Stainless Steel Slider Pins
- Stainless Steel Pad Guides
- Stainless Steel Back Plate for Brake Pads



- Ultra thick, organic, non-asbestos, non-metallic brake pad friction material provides extra long brake pad life. Brake pads slide freely on corrosion resistant stainless steel surfaces



- Retail packaging available



- Heavy duty ventilated rotors dissipate heat rapidly by allowing cooling between the inner and outer brake surfaces. Rotor surface temperatures can rise rapidly from repeated stopping or slowing on mountain grades. Only ventilated rotors can stop this heat from building up to unacceptable levels. Less expensive, non-ventilated rotors overheat causing rapid brake pad deterioration, excessive rotor surface wear and rotor warping.

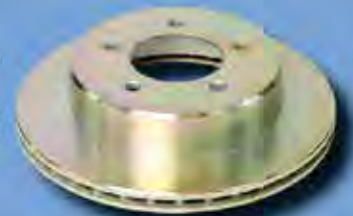

- Rotors available in integral (one piece) and slip-over hat style
- Integral hub & rotor offered in e-coat, Zinc+, and stainless
- Slip-over hat style rotors offered in Zinc+ and stainless steel
- Zinc+ is the most corrosion resistant conversion coating yet to be introduced to the metal finishing industry. This coating can provide over five times the protection when applied over zinc plating.
- Rotors & calipers fit wheels 13" and larger

HUB • HUB & DRUMS



**FULLY GREASED & READY TO ROLL
GALVANIZED UNITS**

• Kits include Spindle Hardware

PREGREASED BOXED GALVANIZED HUB KITS • RETAIL READY

ITEM NO	CAPACITY	BOLT PATTERN	DESCRIPTION
7650071-GV3B	2K	545	PREGREASED BOXED GALVANIZED EZ-LUBE® HUB KIT (1-WHEEL)
7650073-GV3B	3.5K	545	PREGREASED BOXED GALVANIZED HUB KIT (1-WHEEL) - 6-1/2" DIAMETER HUB FLANGE
7650085-GV3B	5.2K	655	PREGREASED BOXED GALVANIZED HUB KIT (1-WHEEL)



1



2



3

GALVANIZED HUBS & HUB KITS

REF NO	ITEM NO	CAPACITY	BOLT PATTERN	DESCRIPTION
	7650012-GV	2K	440	GALVANIZED HUB ONLY (1-WHEEL)
1	7650071-GV3	2K	545	GALVANIZED EZ-LUBE® HUB KIT (1-WHEEL) 5-1/2" HUB FLANGE
	7650073-GV3	3.5K	545	GALVANIZED EZ-LUBE® HUB KIT (1-WHEEL) 6-1/2" HUB FLANGE
	7650077-GV	3.5K	550	GALVANIZED HUB ONLY (1-WHEEL)
2	7650085-GV3	5.2K	655	GALVANIZED EZ-LUBE® HUB KIT (1-WHEEL)
	7650083-GV3	5.2K-7K	865	GALVANIZED EZ-LUBE® HUB KIT (1-WHEEL)
3	7650272	8K	865	GALVANIZED HUB ONLY (1-WHEEL) 9/16" STUDS
3	7650273	8K	865	GALVANIZED HUB ONLY (1-WHEEL) 5/8" STUDS



4

5

6



7

8

9

10

HEX HEAD GRADE 5 ZINC SCREW-IN WHEEL BOLTS

REF NO	ITEM NO	DIAMETER	LENGTH	TYPE	HEAD
	7700008	1/2"-20	0.800	60° CONE	0.800
	7700295	1/2"-20	0.950	90° CONE	0.800
	7700120	9/16"-18	1.120	90° CONE	0.875

GRADE 8 ZINC PRESS-IN WHEEL STUDS

REF NO	ITEM NO	STUD DIAMETER	STUD LENGTH	SPLINE LENGTH	SPLINE DIAMETER	BASE LENGTH
	6450565	1/2"-20	1.688	0.45	0.530	0.60
	6450739	1/2"-20	2.000	0.38	0.545	0.52
	7700123	9/16"-18	2.000	0.31	0.690	0.72
	6450835	9/16"-18	2.500	0.63	0.700	1.10
	7700217	9/16"-18	2.500	0.56	0.689	1.06

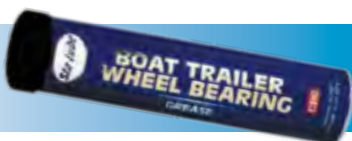

GREASE

ITEM NO	DESCRIPTION
6700085	GREASE 14-OUNCE MARINE STA-LUBE BLUE LUBE



11

12

13

14

15

HEX HEAD ZINC WHEEL NUTS

REF NO	ITEM NO	DIAMETER	GRADE	TYPE
	7700045	1/2"-20	5	60° CONE
	7700285	1/2"-20	5	90° CONE
	7700036	9/16"-18	5	60° CONE
	7700037	9/16"-18	5	90° CONE
	7700048	5/8"-18	5	90° CONE

STAY OUT LONGER WITH THE BRIGHT WAY GROUP MARINE/RV DEEP CYCLE BATTERY



GROUP 24 DEEP CYCLE BATTERY

- Superior Battery that out performs the competition
- No-hassle warranty
- Maintenance free battery



AMERICA'S FASTEST GROWING TRAILER PARTS DISTRIBUTOR!

www.TexTrail.com | 844-TexTrail ★ NOW OPEN IN OSHKOSH, WI

HUB • HUB & DRUM ACCESSORIES

genuine
Bearing Buddy®
 The original... and still the best!
 Millions of bearings owe their lives to it



CHROME BEARING PROTECTORS • RETAIL READY

ITEM NO	I.D. NO	SIZE	TYPICAL USE	DESCRIPTION
7700278	1781	1.781	1K - 2.2K	BEARING BUDDY PROTECTOR WITH BRA (1-PAIR)
7700121	1980	1.980	2.2K-3.5K	BEARING BUDDY PROTECTOR WITH BRA (1-PAIR)
7700210	2328	2.328	3.5K-5.2K	BEARING BUDDY PROTECTOR WITH BRA (1-PAIR)
7700004	2441	2.441	4.4K-5.2K	BEARING BUDDY PROTECTOR WITH BRA (1-PAIR)
7700005	2717	2.717	5.2K-7K	BEARING BUDDY PROTECTOR WITH BRA (1-PAIR)
7700239	70019	1.781" - 1.980"	PROTECTORS	REPLACEMENT VINYL BRA (1-PAIR)
7700214	70023	2.328" - 2.717"	PROTECTORS	REPLACEMENT VINYL BRA (1-PAIR)

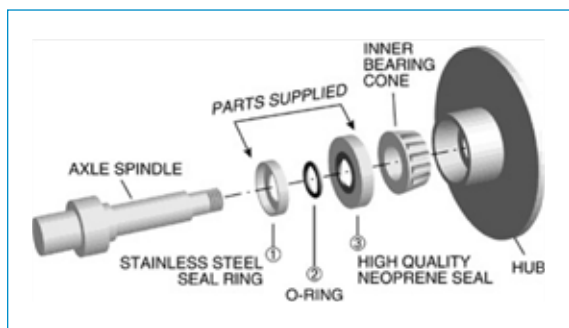

1



2

BEARING BUDDY SPINDLE SEAL KITS • RETAIL READY

REF NO	ITEM NO	I.D. NO	BEARING	USE WITH	DESCRIPTION
	7700335	60001	L44643	1.980" BEARING BUDDY	BEARING BUDDY SPINDLE SEAL KIT (1-PAIR)
1	7700336	60005	L44649	1.980" BEARING BUDDY	BEARING BUDDY SPINDLE SEAL KIT (1-PAIR)
2	7700337	60002	L68149	1.980" BEARING BUDDY	BEARING BUDDY SPINDLE SEAL KIT (1-PAIR)
	7700338	60011	25580	2.441" BEARING BUDDY	BEARING BUDDY SPINDLE SEAL KIT (1-PAIR)

REPLACEMENT UFP OIL SEALS • 2 PACK

ITEM	DESCRIPTION	CAPACITY	SIZE
7700273	UFP UNIQUE HUB OIL SEAL	3.2K - 4.2K	2.56"OD x 1.68"ID
7700271	UFP UNIQUE HUB OIL SEAL #42	5.2K - 6K	3.26"OD x 2.13"ID



•Oil Seals



•EZ-Lube® Cap Kit

CHROME HUB GREASE CAP KITS • RETAIL READY

ITEM NO	I.D. NO	FITS	TYPICAL USE	DESCRIPTION
7700025-01	K71-315-00	1.986	2K-3.5K	DRIVE-IN STANDARD EZ-LUBE® CAP KIT (2-EA CAPS & PLUGS)
7700016-01	K71-317-00	2.450	4.4K-5.2K	DRIVE-IN STANDARD EZ-LUBE® CAP KIT (2-EA CAPS & PLUGS)
7700018-01	K71-319-00	2.720	5.2K-7K	DRIVE-IN STANDARD EZ-LUBE® CAP KIT (2-EA CAPS & PLUGS)
7700053-01	K71-320-00	ALL	EZ-LUBE® CAP	EZ-LUBE® CAP PLUG KIT DEXTER OEM REPLACEMENT (2-EA PLUGS)



HUB • HUB & DRUM ACCESSORIES



The VAULT™ "Hybrid Lubrication System" uses a semi-fluid oil in a pressurized chamber to give you the ultimate in wheel bearing lubrication and protection. At ambient temperature, the Hybrid Oil™ lubrication is thick with a viscosity approaching grease. As the bearing temperature rises during towing, the lubricant thins out, replenishing the bearing, reducing friction and dissipating heat. No inspection, no maintenance and no service required.



• Vault Service Kit

Benefits:

- 10 Year (unlimited miles), warranty available.
- Pressurized sealed chamber means nothing gets in or out.
- Stainless steel components, high temperature piston.
- Constantly replenishes the lubrication to the bearing.
- Bearings run cooler due to reduced friction.
- No visual inspection required.
- No access hole in wheel centers, allows for better looking wheel.
- No maintenance/service provides lower operating costs.

VAULT SERVICE KIT

ITEM NO	ITEM NO	FITS
7700310	K71-030-00	2.5K, 3.2K, 3.5K 545 1.980" OUTER BORE
7700309	K71-029-00	4.2K 545 & 5.2K 655 2.328" OUTER BORE
	K71-028-00	6K 655 2.411" OUTER BORE
	K71-027-00	7K 865 2.717" OUTER BORE

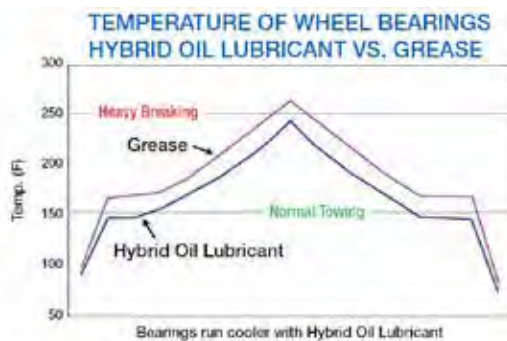

SEE THE VAULT™ DIFFERENCE - COMPARED

THE VAULT™	GREASE	OIL
ALL ADVANTAGES <ul style="list-style-type: none"> • BEARINGS RUN COOLER • NO INSPECTION REQUIRED • NO MAINTENANCE REQUIRED • NO SERVICE REQUIRED 	ADVANTAGES <ul style="list-style-type: none"> • Dependable system • Adheres to bearings • Will not leak out of hub • Works in pressurized systems DISADVANTAGES <ul style="list-style-type: none"> • Bearings run hotter • Increased friction • Increased bearing wear • Doesn't replenish the lubricant to the bearing • Regular service required 	ADVANTAGES <ul style="list-style-type: none"> • Bearings run cooler • Reduced friction • Prolonged bearing life • Constantly replenishes lubrication to the bearing DISADVANTAGES <ul style="list-style-type: none"> • Leaks are hard to control • Not to be used in pressurized systems • Complete loss of oil can lead to catastrophic failure • Regular service required



NEVER GREASE REPLACEMENT HUBS AGAIN!



WHY DO THIS WHEN YOU CAN BUY A FULLY GREASED REPLACEMENT HUB?

FEATURES

- 100% Pre-greased Bearing and Hub Cavity
- Pre-assembled Grease Seal and Bearings
- Save Time, Labor, and Money
- Easy To Install



Galvanized Kit #	Description	Bearings
7650071-GV3B	Galvanized 2K Hub Kit 5 on 4.50" Bolt Pattern 5.5" Hub Flange Diameter	Uses L44649 Inner & Outer
7650073-GV3B	Galvanized 3.5K Hub Kit 5 on 4.50" Bolt Pattern	Uses L68149 Inner & L44649 Outer
7650085-GV3B	Galvanized 5.2K Hub Kit 6 on 5.50" Bolt Pattern	Uses 25580 Inner & 15123 Outer

AMERICA'S FASTEST GROWING TRAILER PARTS DISTRIBUTOR!

www.TexTrail.com | 844-TexTrail

SUSPENSION =

GALVANIZED AXLE SEAT

REF NO	ITEM NO	DESCRIPTION
1	9000573	2" SLIDING SADDLE

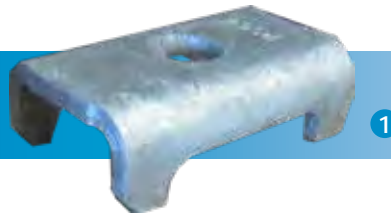

1

THICK SHACKLE STRAPS

REF NO	ITEM NO	DESCRIPTION	A	B	C	HOLE SIZE	THICKNESS
	9000304	GALVANIZED SHACKLE STRAP	4"	2-9/16"	1-1/4"	9/16"	.50
	9000162	GALVANIZED SHACKLE STRAP	3-3/4"	2-1/4"	1-1/4"	9/16"	.50
2	9000632	GALVANIZED SHACKLE STRAP	3-3/4"	2-1/4"	1-1/4"	9/16"	.25

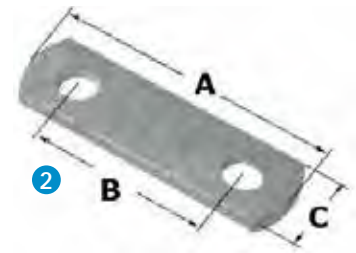

2

SHACKLE BOLT & NUT

REF NO	ITEM NO	DESCRIPTION
3	9000335	ZINC PLATED HEX NUT 9/16"-18
4	9000336	ZINC PLATED HEX HEAD SHACKLE BOLT 9/16"-18 X 3" LONG



3

4



5



6

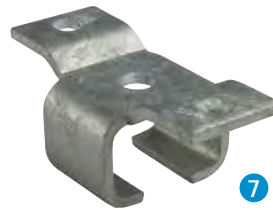

7

BOLT-ON HANGERS

REF NO	ITEM NO	DESCRIPTION	SPRING TYPE
5	9000583	GALVANIZED FRONT HANGER 2-HOLE 9/16" BOLT HOLE 4-1/4"	DOUBLE-EYE
6	8270044	GALVANIZED FRONT HANGER 2-HOLE 9/16" BOLT HOLE 5/3/8"	DOUBLE-EYE
7	8270045	GALVANIZED REAR HANGER 4-HOLE 9/16" BOLT HOLE HEAVY DUTY	SLIPPER

MARINE AXLE TIE PLATES

REF NO	ITEM NO	DESCRIPTION
	8270047	GALVANIZED AXLE TIE PLATE FOR 1-1/2" SQUARE TUBE AXLES FOR 1/2" U-BOLT
8	8270046	GALVANIZED AXLE TIE PLATE FOR 2" SQUARE TUBE AXLES 4" X 3.81" FOR 1/2" U-BOLT
9	9000218	ZINC AXLE TIE PLATE 3-HOLE 5" END TO END 3.56" U-BOLT HOLE CENTERS 1-1/2" • WIDE FOR USE WITH 1/2" U-BOLTS

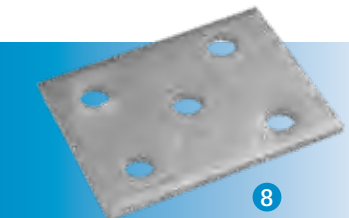

8



9



10



11

U-BOLTS, AXLE TIE PLATES & HARDWARE KITS

REF NO	ITEM NO	DESCRIPTION	U-BOLT SIZE	FINISH
10	9100270	FITS 2" SQUARE TUBE AXLES	1/2"-13 X 5.31" LONG	GALVANIZED
11	9100160	FITS 2" SQUARE TUBE AXLES	1/2"-13 X 5.38" LONG	ZINC
	9100323	**FITS 2" SQUARE TUBE AXLES	3/8"-16 X 3.50" LONG	YELLOW ZINC
	9100315	**FITS 2" SQUARE TUBE AXLES	3/8"-16 X 3.00" LONG	ZINC
	9100318	**FITS 3" SQUARE TUBE AXLES	3/8"-16 X 4.00" LONG	ZINC

**U-Bolt and Hardware Kit Only. Less Axle Tie Plate.

U-BOLTS =



SQUARE U-BOLTS		
REF NO	ITEM NO	DESCRIPTION
	9000303	SQUARE U-BOLT 1-5/8" X 3/8" DIAMETER X 2.50" LONG STAINLESS STEEL
	9000507	SQUARE U-BOLT 2" X 1/2" DIAMETER X 4.3" LONG STAINLESS STEEL
	9000508	SQUARE U-BOLT 2" X 1/2" DIAMETER X 5.3" LONG STAINLESS STEEL
1	9000509	SQUARE U-BOLT 2" X 1/2" DIAMETER X 6.3" LONG STAINLESS STEEL
	9000510	SQUARE U-BOLT 3" X 1/2" DIAMETER X 5.3" LONG STAINLESS STEEL
	9000289	SQUARE U-BOLT 3" X 1/2" DIAMETER X 4-1/2" LONG STAINLESS STEEL
	9000338	SQUARE U-BOLT 3" X 3/8" DIAMETER X 3.88" LONG STAINLESS STEEL
	9000501	SQUARE U-BOLT 2" X 1/2" DIAMETER X 4.3" LONG GALVANIZED
	9000502	SQUARE U-BOLT 2" X 1/2" DIAMETER X 5.3" LONG GALVANIZED
	9000503	SQUARE U-BOLT 2" X 1/2" DIAMETER X 6.3" LONG GALVANIZED
	9000504	SQUARE U-BOLT 3" X 1/2" DIAMETER X 4.31" LONG GALVANIZED
2	9000505	SQUARE U-BOLT 3" X 1/2" DIAMETER X 5.31" LONG GALVANIZED
	9000506	SQUARE U-BOLT 3" X 1/2" DIAMETER X 6.31" LONG GALVANIZED
3	9000403	SQUARE U-BOLT 2" X 1/2" DIAMETER X 4.3" LONG ZINC PLATED
	9000317	SQUARE U-BOLT 2" X 1/2" DIAMETER X 5-3/8" LONG ZINC PLATED
	9000397	SQUARE U-BOLT 2" X 3/8" DIAMETER X 2-1/2" LONG ZINC PLATED
	9000500	SQUARE U-BOLT 3" X 1/2" DIAMETER X 4.31" LONG ZINC PLATED
	9000339	SQUARE U-BOLT 3" X 3/8" DIAMETER X 3.88" LONG ZINC PLATED
	9000511	SQUARE U-BOLT 3.125" X 1/2" DIAMETER X 3.875" LONG ZINC PLATED



ROUND U-BOLTS		
REF NO	ITEM NO	DESCRIPTION
4	9000496	ROUND U-BOLT 1.75" X 3/8" DIAMETER X 4" LONG ZINC PLATED
	9000319	ROUND U-BOLT 2.38" X 1/2" DIAMETER X 5.50" LONG ZINC PLATED

NUTS & WASHERS

ITEM NO	DESCRIPTION	ITEM NO	DESCRIPTION
7030199	1/2" STAINLESS STEEL LOCK WASHER	7030202	1/2"-13 STAINLESS STEEL HEX NUT
7030204	1/2" GALVANIZED LOCK WASHER	7030139	3/8"-16 STAINLESS STEEL HEX NUT
9000251	1/2" ZINC PLATED LOCK WASHER	7030203	1/2"-13 GALVANIZED HEX NUT
9000250	3/8" ZINC PLATED LOCK WASHER	7030069	1/2"-13 ZINC PLATED HEX NUT
		6450182	3/8"-24 ZINC PLATED HEX NUT



BOLSTER BRACKETS



GALVANIZED DOUBLE U-BOLT BRACKETS

REF NO	ITEM NO	ID NO	DESCRIPTION	HEIGHT	WIDTH
1	8270007	10190G	DOUBLE U-BOLT BRACKET	8.75"	4"
2	8270008	10191G	DOUBLE U-BOLT BRACKET	9.75"	4"
3	8270020	10192G	DOUBLE U-BOLT BRACKET	11.75"	4"

Often the Double U-Bolt Bracket is used in lieu of the Bolster Brackets listed below.



•BOLSTER BRACKET



•TOP SWIVEL BRACKET



•HD TOP SWIVEL BRACKET

NOTE: 1" IS ADDED TO HEIGHT WHEN SWIVEL BRACKET IS ATTACHED TO BOLSTER BRACKET.

GALVANIZED ADJUSTABLE BOLSTER BRACKETS USED TO SUPPORT TRAILER BUNKS

REF NO	ITEM NO	ID NO	DESCRIPTION
4	8270034	10100G	8" ADJUSTABLE BOLSTER BRACKET 2-1/2" WIDE, TWO 1/2" X 2-3/4" SLOTS
	8270041	10101G	10" ADJUSTABLE BOLSTER BRACKET 2-1/2" WIDE, TWO 1/2" X 2-3/4" SLOTS
	8270035	10102G	12" ADJUSTABLE BOLSTER BRACKET 2-1/2" WIDE, TWO 1/2" X 2-3/4" SLOTS

GALVANIZED ANGLED BRACKET • TOP SWIVEL BOLSTER BRACKET

REF NO	ITEM NO	ID NO	DESCRIPTION
5	8270048	10200G	SWIVEL BRACKET FOR MOUNTING BUNK BOARDS TO BOLSTER BRACKET. 2" X 3-1/2" X 1-3/8" G90 GALVANIZED. HOLES ARE 13/32" ON 2-1/2" CENTERS.
6	8270049	10204G	HD SWIVEL BRACKET FOR MOUNTING BUNK BOARDS TO BOLSTER BRACKET. 1-3/4" X 2" X 1-1/4" G90 GALVANIZED. HOLES ARE 7/16".

GUIDE-ONS & BRACKETS



TWO ALUMINUM 1-1/2" SQUARE TUBES WITH HEAVY DUTY 1/8" WALL COVERED WITH 2" SCHEDULE 160 PVC PIPE. OVERALL HEIGHT IS 65". FITS CONVENIENTLY INTO SOCKET BUILT INTO MOST BOAT TRAILERS, OR MAY BE ATTACHED TO FRAME WITH GUIDE-ON BRACKETS AND U-BOLTS. SOLD IN PAIRS. NON-LIGHTED.

ALUMINUM TUBE PVC POST GUIDE-ON

REF NO	ITEM NO	DESCRIPTION
1	8270171	65" PVC POST GUIDE-ON 1-1/2" SQUARE ALUMINUM TUBE

GALVANIZED TUBE PVC POST GUIDE-ON

REF NO	ITEM NO	DESCRIPTION
2	8270063	40" PVC POST GUIDE-ON 1-1/2" SQUARE GALVANIZED TUBE
	8270130	60" PVC POST GUIDE-ON 1-1/2" SQUARE GALVANIZED TUBE

TWO GALVANIZED 1-1/2" SQUARE TUBES ARE COVERED WITH 2" SCHEDULE 40 PVC PIPE. FITS CONVENIENTLY INTO SOCKET BUILT INTO MOST BOAT TRAILERS, OR MAY BE ATTACHED TO FRAME WITH GUIDE-ON BRACKETS AND U-BOLTS. SOLD IN PAIRS. NON-LIGHTED.



BUNKBOARD GUIDE-ONS

REF NO	ITEM NO	DESCRIPTION
3	8270086	60" BUNKBOARD GUIDE-ON

NOTE: 8270086 REQUIRES 2-EA 8270172 GUIDE-ON MOUNTING KITS PER TRAILER.



TUBULAR FRAME GUIDE-ON GALVANIZED MOUNTING BRACKET KIT

REF NO	ITEM NO	DESCRIPTION
4	8270172	BRACKET KIT FOR MOUNTING GUIDE-ON TUBES TO FRAME



I-BEAM FRAME GUIDE-ON GALVANIZED MOUNTING BRACKET KIT

REF NO	ITEM NO	DESCRIPTION
5	8270156	BRACKET KIT FOR MOUNTING GUIDE-ON TUBES TO FRAME



GALVANIZED GUIDE-ON V-BAR BRACKET

REF NO	ITEM NO	DESCRIPTION
6	8270038	GUIDE-ON V-BAR BRACKET MOUNTS 2" SQUARE TUBE VERTICALLY TO FRAME CROSS MEMBER. COMMONLY USED TO MOUNT BOW GUIDE. 9/16" HOLES MOUNT ON 2" CENTERS. 7-GAUGE STEEL.



ROLLER & BUNK BRACKETS



GALVANIZED ADJUSTABLE ROLLER BRACKETS

REF NO	ITEM NO	ID NO	DESCRIPTION
1	8270039	10301G	5" ROLLER BRACKET 3" MOUNTING CENTER FOR 5/8" SHAFT 5 SLOTS 17/32" SLOT
2	8270042	10303G	8" ROLLER BRACKET 6" MOUNTING CENTER FOR 5/8" SHAFT 5 SLOTS 17/32" SLOT
3	8270040	10304G	10" ROLLER BRACKET 8" MOUNTING CENTER FOR 5/8" SHAFT 5 SLOTS 17/32" SLOT
4	8270043	10101G	12" ROLLER BRACKET 10" MOUNTING CENTER FOR 5/8" SHAFT 5 SLOTS 17/32" SLOT

GALVANIZED SPLIT ADJUSTABLE ROLLER BRACKETS

REF NO	ITEM NO	ID NO	DESCRIPTION
5	8270084	10525G	LEFT HAND ROLLER BRACKET, 5/8" SHAFT, 5 SLOTS, 17/32" SLOT
6	8270085	10550G	RIGHT HAND ROLLER BRACKET, 5/8" SHAFT, 5 SLOTS, 17/32" SLOT

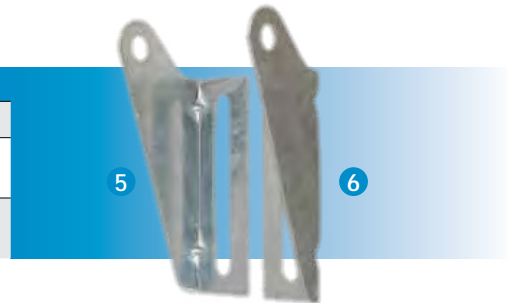

GALVANIZED SPLIT KEEL ROLLER BRACKET

REF NO	ITEM NO	ID NO	DESCRIPTION
7	8270129	32001G	GUIDE-ON BRACKET 9/16" HOLES. MOUNTS 2" SQUARE TUBES TO FRAME.

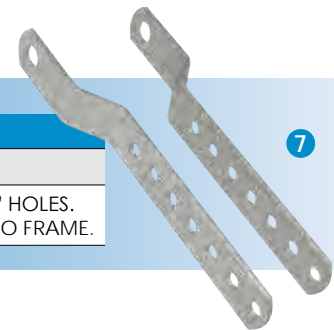

ZINC PLATED ROLLER SHAFTS

REF NO	ITEM NO	ID NO	DESCRIPTION
8	7950098	80480	1/2" X 12" ZINC ROLLER SHAFT
9	8270050	10721	5/8" X 5-1/4" ZINC ROLLER SHAFT
	8270051	10725	5/8" X 9-1/4" ZINC ROLLER SHAFT
10	8270052	10726	5/8" X 11-1/8" ZINC ROLLER SHAFT
	8270053	10727	5/8" X 13-1/2" ZINC ROLLER SHAFT

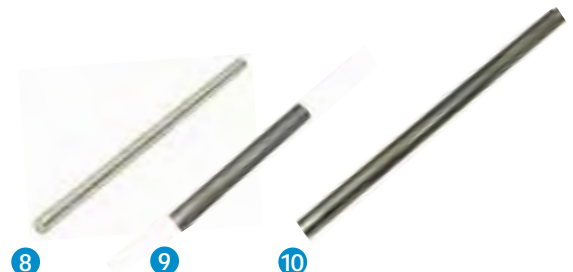

ROLLER & BUNK BRACKETS, CONT. • CARPETING •



ZINC PLATED PAL NUTS

ITEM NO	ID NO	DESCRIPTION
8270054	10801	5/8" ZINC PAL NUT



PONTOON GALVANIZED V-BRACKET

ITEM NO	ID NO	DESCRIPTION
8270006	26244G	MEDIUM WING V-BRACKET. 7" LATERAL ADJUST SLOTS



GALVANIZED VERTICAL BUNK BRACKETS

REF NO	ITEM NO	ID NO	DESCRIPTION	WIDTH
1	8270036	10161G	8" HEAVY DUTY VERTICAL BUNK BRACKET	5" WIDE
2	8270037	10162G	10" HEAVY DUTY VERTICAL BUNK BRACKET	5" WIDE



LANCED GALVANIZED VERTICAL BUNK BRACKETS

REF NO	ITEM NO	ID NO	DESCRIPTION
3	8270103	10600G	9-1/2" LANCED VERTICAL BUNK BRACKET 7/16" X 6" SLOT. 11-GAUGE.



BUNK CARPETING

REF NO	ITEM NO	ID NO	DESCRIPTION
4	8270072	CR8008	MARINE GRADE BUNK CARPETING 8" X 12-FOOT
	8270073	CR8012	MARINE GRADE BUNK CARPETING 12" X 12-FOOT



WINCH POSTS • TUBE CAPS • GALVANIZE SPRAY PAINT

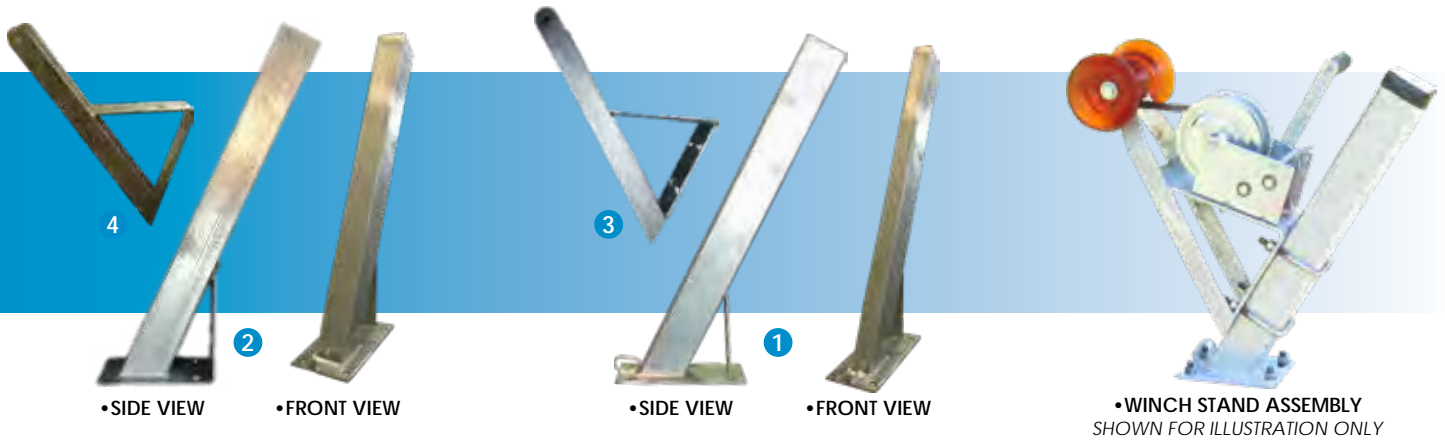

GALVANIZED WINCH POSTS 0.120 GAUGE		
REF NO	ITEM NO	DESCRIPTION
1	9850083	WINCH POST 2" X 4" X 3/16" WALL X 35" LONG
2	9850085	WINCH POST 3" X 4" X 3/16" WALL X 35" LONG
3	9850084	WINCH POST TOP 2" X 4" X 3/16" WALL
4	9850089	WINCH POST TOP 3" X 4" X 3/16" WALL



PVC Tube Caps have universal applications. Guide-On Upright Caps, Fender Step Pad End Caps, Winch Post Caps, Spare Tire Mount Caps and any other use you can determine is a good application.

PVC TUBE CAPS		
REF NO	ITEM NO	DESCRIPTION
5	8530026	2" X 4" PVC TUBE CAP
6	8530033	3" X 3" PVC TUBE CAP
	8530028	3" X 4" PVC TUBE CAP
7	8270024	2" X 4" PVC TUBE ANGLE CAP

GALVANIZE SPRAY COATING		
REF NO	ITEM NO	DESCRIPTION
8	8500216	12-OZ COLD SPRAY GALVANIZE PAINT
9	8500215	12-OZ BRITE SPRAY GALVANIZE PAINT



WINCH POSTS • TUBE CAPS • GALVANIZE SPRAY PAINT

WINCHES =



HAND WINCHES								
REF NO	ITEM NO	DESCRIPTION	CAPACITY	GEAR RATIO	STRAP	FREE SPOOL	STORAGE	
	9850167	SINGLE SPEED WINCH	0.6K	4.4:1	YES	OFF	23'	
	9850168	SINGLE SPEED WINCH	1.4K	4.4:1	YES	OFF	23'	
1	9850169	SINGLE SPEED WINCH	1.6K	4.4:1	YES	OFF	23'	
2	9850073	SINGLE SPEED WINCH	1.6K	5.4:1	NO	OFF	45'	
3	9850074	SINGLE SPEED WINCH	1.8K	5.4:1	NO	CENTER	38'	
4	9850075	2-SPEED WINCH	2.0K	12.4:1/5.4:1	NO	CENTER	38'	
5	9850076	2-SPEED WINCH	2.5K	17.3:1/4.1:1	NO	CENTER	38'	
6	9850111	2-SPEED WINCH	3.2K	17.3:1/4.1:1	NO	CENTER	30'	
7	9850146	2-SPEED WINCH BRAKE	3.5K	12:1/6:1	NO	CENTER	37'	
	9850102	9-1/2" QUICK DISCONNECT HANDLE FOR DL2500/3500 MANUAL HAND WINCHES						



WINCH STRAPS & CABLE				
REF NO	ITEM NO	DESCRIPTION	WLL	SIZE
	9850179	WINCH STRAP WITH HOOK	1.4K	2" X 15'
8	9850178	WINCH STRAP WITH HOOK	1.4K	2" X 20'
9	9850018	WINCH STRAP WITH HOOK	2.6K	2" X 20'
10	9850095	WINCH STRAP WITH HOOK	4K	2" X 20'



FENDERS

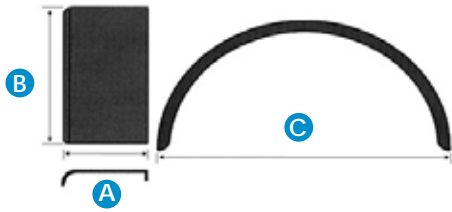

ALUMINUM TRAILER FENDERS

REF NO	ITEM NO	ID NO	DESCRIPTION	A	B	C	GAUGE
1	7050262	A6856-063	SINGLE SMOOTH ALUMINUM SQUARE BROKE FENDER	8"	9"	28"	0.063
	7050347	A6747-063	SINGLE ALUMINUM TREADPLATE SQUARE BROKE FENDER	10"	13"	32"	0.063
2	7050311	MFJ116	SINGLE ALUMINUM TREAD PLATE DOUBLE SQUARE BROKE FENDER	10"	16"	32"	0.080
3	7050236	A6401TP-063	SINGLE ALUMINUM TREAD PLATE FENDER	9"	15"	32"	0.063
4	7050302	17100ATB	SINGLE ALUMINUM TREAD PLATE FENDER	10"	16"	32"	0.100
5	7050156	A6091BTP-063	TANDEM ALUMINUM TREAD PLATE FENDER	9"	18"	72"	0.063
6	7050303	17312ATB	TANDEM ALUMINUM TREAD PLATE FENDER	10"	17"	68"	0.080
7	7050312	MFJ123	TANDEM ALUMINUM TREAD PLATE DOUBLE SQUARE BROKE FENDER	10"	16"	68"	0.100
8	7050261	A6056-CTP	TANDEM TEAR DROP ALUMINUM TREAD PLATE FENDER	10-3/4"	18"	72"	0.063
9	7050306	7168	TRIPLE ALUMINUM TREAD PLATE FENDER	12"	18"	110"	0.100

FENDERS • FENDER MOUNTING BRACKETS



•TYPE A



•TYPE B

POLY TRAILER FENDERS

TYPE	ITEM NO	ID NO	DESCRIPTION	STEP	COLOR	WIDTH	HEIGHT	LENGTH
A	7050151	008553	SINGLE POLY FENDER FOR 13" TIRE & WHEEL ASSEMBLIES	TOP	BLACK	9.7"	12"	29"
B	7050498	008583	SINGLE POLY FENDER FOR 13" TIRE & WHEEL ASSEMBLIES	TOP & ENDS	BLACK	9.7"	12.65"	42.75"
B	7050481	008585	SINGLE POLY FENDER FOR 14" TIRE & WHEEL ASSEMBLIES	TOP & ENDS	BLACK	9.7"	12.75"	43.4"
B	7050406	008584	SINGLE POLY FENDER FOR 15" TIRE & WHEEL ASSEMBLIES	TOP & ENDS	BLACK	10.5"	14.85"	45"



1



2

FENDER MOUNTING BRACKETS

REF NO	ITEM NO	DESCRIPTION
1	8270176	GALVANIZED FENDER MOUNTING BRACKET. FOR 8" OR 9" WIDE FENDERS.
2	8270177	GALVANIZED FENDER MOUNTING BRACKET KIT FOR MOUNTING PLASTIC FENDERS. INCLUDES LEFT HAND AND RIGHT HAND BRACKET AND 8 FENDER SCREWS.

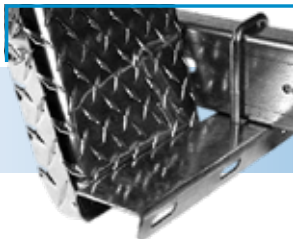

FENDER STEP PADS

ITEM NO	DESCRIPTION
8270175	3" X 15-1/4" LONG 12-GA GALVANIZED FENDER STEP PAD



SLIDES & WRAPS

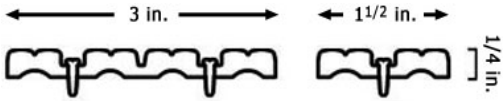

NOTE: ACTUAL DIMENSIONS OF THE PRODUCT



MARINE SLIDES				
ITEM NO	ID NO	DESCRIPTION	SIZE	QTY
8270057	23011	WHITE 1/4" CHANNEL PROFILE BUNK SLIDES	3" X 15"	10-EA

Bunk Wrap

- Reduce force required to load or unload your boat by over 300%.
- Less strain on arms, ropes and pulleys.
- Eliminate the fine particles of sand embedded into the carpet to grind away at your gel coat.
- Wash out channels flush sand, salt and other debris away from the hull.
- Guaranteed not to crack, chip, or wear out, and is impervious to sun and salt.

Improvement with Bunk Wrap • Problems Addressed:

1. **SIZING:** Profile size of Bunk Wrap (Both 2x4 & 2x6) are too large and leave more than 1/4" to 3/8" gap on the width and height of the bunk board, if not wrapped over carpet.
+NEW NARROW SIZING: Better fit for 2x4 and 2x6 widths. Going over carpet is no longer an option.
2. **LIVING HINGES:** Rolled Bunk Wrap has been hard to bend at living hinge areas.
+NEW HINGE DESIGN: 50% stronger & 10% reduction in bend force because of longer hinge design transition.
3. **END CAPS:** Sized too large for both 2x4 & 2x6.
+NEW END CAPS: 4-Sided flexible flange that holds part in 4 locations around board. "Optional" screw pockets on end cap (only required in consumer kit unless using OEM Recommended 1-1/2" Staples.)
4. **STAPLE FLANGE:** Too short and domed making it hard to staple Bunk Wrap to bunk board.
+NEW 3/8" longer tabs for more flexibility. Dented notches and trough for easy staple gun placement.

TRAILER BUNK WRAPS • PLASTIC			
ITEM NO	ID NO	DESCRIPTION	SIZE
8270017	CR0408	GREY PLASTIC BUNK COVER	2" X 4" X 8'
8270018	CR0410	GREY PLASTIC BUNK COVER	2" X 4" X 10'
8270016	CR0412	GREY PLASTIC BUNK COVER	2" X 4" X 12'
8270003	CR0606	GREY PLASTIC BUNK COVER	2" X 6" X 6'
8270004	CR0608	GREY PLASTIC BUNK COVER	2" X 6" X 8'
8270005	CR0610	GREY PLASTIC BUNK COVER	2" X 6" X 10'
8270001	CR0612	GREY PLASTIC BUNK COVER	2" X 6" X 12'
8270019	CR0401	GREY END CAP	2" X 4"
8270002	CR0601	GREY END CAP	2" X 6"

BULK • TRAILER BUNK WRAPS • PLASTIC • 1000' ROLL			
ITEM NO	ID NO	DESCRIPTION	SIZE
8270087	CR1002	GREY PLASTIC BUNK COVER	2" X 6"
8270133	CR1002-BK	BLACK PLASTIC BUNK COVER	2" X 6"
8270002	CR0601	GREY END CAP	2" X 6"
8270154	CR0601-BK	BLACK END CAP	2" X 6"

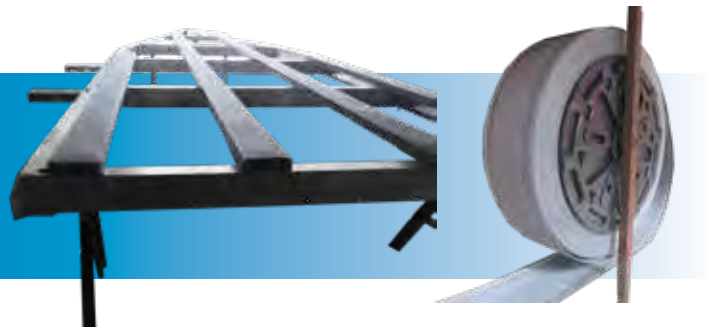

- Tough UV-resistant poly vinyl
- Cut resistant and shock absorbent
- No marring or scratching to your watercraft



PVC • END BELL

ITEM NO	ID NO	DESCRIPTION	COLOR	SHAFT
8270029	27230-BLUE	3" END BELL	BLUE	1/2"
8270012	27240-BLUE	4" END BELL	BLUE	1/2"
8270061	27240	4" END BELL	YELLOW	1/2"

PVC • END CAP

ITEM NO	ID NO	DESCRIPTION	COLOR	SHAFT
8270066	27215-BLUE	3-1/2" END CAP	BLUE	1/2"

PVC • KEEL ROLLERS

ITEM NO	ID NO	DESCRIPTION	ACTUAL LENGTH	COLOR	SHAFT
8270033	25208	8" KEEL ROLLER - HEAVY DUTY	7-7/8"	YELLOW	5/8"
8270058	25210	10" KEEL ROLLER - HEAVY DUTY	9-7/8"	YELLOW	5/8"
8270032	25212	12" KEEL ROLLER - HEAVY DUTY	11-7/8"	YELLOW	5/8"
8270067	25212-B	12" KEEL ROLLER	11-7/8"	BLUE	5/8"

PVC • BOW ROLLERS

ITEM NO	ID NO	DESCRIPTION	COLOR	SHAFT
8270028	23230-BLUE	3" BOW ROLLER	BLUE	1/2"
8270009	23241-BLUE	4" BOW ROLLER V-TYPE	BLUE	1/2"
8270060	23241-YELLOW	HD 4" BOW ROLLER V-TYPE	YELLOW	1/2"

PVC • KEEL PAD

ITEM NO	ID NO	DESCRIPTION	COLOR
8270062	29202	3" X 12" KEEL PAD	YELLOW
8270013	29202-BLUE	3" X 12" KEEL PAD	BLUE





Rubber Boat Rollers

- Tough UV-resistant black rubber
- Cut resistant and shock absorbent
- No marring or scratching to your watercraft

RUBBER • KEEL ROLLERS

REF NO	ITEM NO	ID NO	DESCRIPTION	COLOR	SHAFT
1	8270031	05-8000	8" KEEL ROLLER	BLACK	5/8"
2	8270059	25110	10" KEEL ROLLER	BLACK	5/8"
3	8270030	25112	12" KEEL ROLLER	BLACK	5/8"

RUBBER • SIDE GUIDE ROLLER

REF NO	ITEM NO	ID NO	DESCRIPTION	COLOR	SHAFT
4	8270021	29193	2-1/2" X 8-3/4" SIDE GUIDE	BLACK	3/4"



RUBBER • BOW GUARD V-STOPS

REF NO	ITEM NO	ID NO	DESCRIPTION	COLOR	SHAFT
5	8270104	29124	2" X 2" BOW V-STOP	BLACK	3/8"
6	8270010	29136	3" X 3" BOW V-STOP	BLACK	1/2"
7	8270027	29147	4" X 4" BOW V-STOP	BLACK	1/2"
8	8270126	29553	3" X 3" BOW JOHN STOP BLOCK 5-1/2" SPAN	BLACK	3/4"

RUBBER • SPOOL ROLLER

REF NO	ITEM NO	ID NO	DESCRIPTION	COLOR	SHAFT
9	8270064	23142	4" SPOOL ROLLER	BLACK	5/8"

RUBBER • BOW ROLLER

REF NO	ITEM NO	ID NO	DESCRIPTION	COLOR	SHAFT
10	8270011	INJ40201	HD BOW ROLLER 3" X 3" BUCHANNAN	BLACK	1/2"

RUBBER • BOW ROLLER END CAP

REF NO	ITEM NO	ID NO	DESCRIPTION	SIZE	SHAFT
11	8270055	224-5	BOW ROLLER END CAP	2-1/2" X 2-1/2"	5/8"

RUBBER - KEEL PAD

REF NO	ITEM NO	ID NO	DESCRIPTION	COLOR
12	8270023	40101-TPO	1-1/2" X 10" KEEL PAD	BLACK

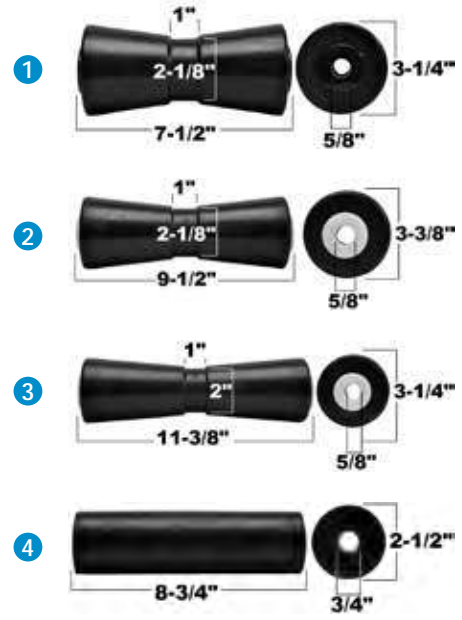



T15

NEWarrival



**ANOTHER AWARD WINNING
SENDEL TOWABLE
WITH DIRECTIONAL STYLING**

- GLOSS BLACK OR FULL SILVER PAINTED
- SAE J1204 COMPLIANT
- OVER 40 YEARS OF QUALITY AUTOMOTIVE PRODUCTS
- PICTURED WITH OUR OPTIONAL APPLICATION SPECIFIC SENDEL EZ LUBE CAPS IN NUMEROUS COLORS
- FEATURING OUR LATEST TORQUE LOCK TECHNOLOGY WHICH INSURES THE PROPER AMOUNT OF LUG TORQUE

Part Number	CAP #	SIZE	Bolt	Hub	Max	Max	ET
T15-45545BM/S	S1050-319	14X5.5	5X4.5	3.19	2,200	65 PSI	+0
T15-55545BM/S	S1050-319	15x5	5x4.5	3.19	1,870	80 PSI	+0
T15-56545BM/S	S1050-319	15X6	5X4.5	3.19	2,150	60 PSI	+0
T15-56550BM/S	S1050-319	15X6	5X5.0	3.19	2,150	80 PSI	+0
T15-56655BM/S	S1050-375	15X6	6X5.5	3.75	2,850	80 PSI	+0
T15-66655BM/S	S1050-375	16X6	6X5.5	3.75	3,200	80 PSI	+0
T15-66867BM/S	S1050-490	16X6	8X6.5	4.90	3,750	110 PSI	+0

TIRE & WHEEL ASSEMBLIES



THE ULTIMATE IN TREADWEAR LIFE! GOODRIDE®



ST100
HEAT-LESS

Special HEAT-LESS technology utilizes heat resistant compounding to slow down tire aging and extend tire life.

Double steel belts for enhanced strength improving puncture resistance and vehicle towing stability.

Long life and low rolling resistance reduces tread wear and improves fuel economy.

Full nylon cap for added strength and durability

10/32" Automotive tread depth



AMERICA'S FASTEST GROWING TRAILER PARTS DISTRIBUTOR!

www.TexTrail.com | 844-TexTrail

TIRE & WHEEL ASSEMBLIES

Galvanized Wheel & Tire Assemblies



GOODRIDE



BIAS

Bias construction nylon ply is ideal for many towable applications including boat trailers, utility trailers, stock trailers, and recreational vehicles. Meets or exceeds FMVSS 119.

RADIAL

Radial tire features double polyester cord body, double steel belts and nylon overlays which contribute up to 15% more endurance in loading conditions when compared to other brands. Meets or exceeds FMVSS 119 & FMVSS 139.



•9400074



•9400362



•940164



•940216



•940219

8" - 12" DIAMETER TIRE & WHEEL ASSEMBLIES

BIAS	9400362	4.80 X 8 BIAS PLY LOAD RANGE B TIRE ON 8" X 3-3/4" GALVANIZED OEM 545 WHEEL
	9400394	4.80 X 8 BIAS PLY LOAD RANGE C TIRE ON 8" X 3-3/4" GALVANIZED OEM 545 WHEEL
	9400404	205/65-10 BIAS PLY LOAD RANGE E TIRE ON A 10" X 6" GALVANIZED OEM 545 WHEEL
	9400074	4.80 X 12 BIAS PLY LOAD RANGE C TIRE ON 12" X 4" GALVANIZED SPOKE 545 WHEEL
	9400387	4.80 X 12 BIAS PLY LOAD RANGE C TIRE ON 12" X 4" GALVANIZED MODULAR 545 WHEEL
	9400318	5.30 X 12 BIAS PLY LOAD RANGE C TIRE ON 12" X 5" GALVANIZED SPOKE 545 WHEEL
RADIAL	9400771	5.30 X 12 BIAS PLY LOAD RANGE C TIRE ON 12" X 5" GALVANIZED MODULAR 545 WHEEL

13" - 14" DIAMETER TIRE & WHEEL ASSEMBLIES

BIAS	9400164	ST175/80 BIAS PLY LOAD RANGE C TIRE ON A 13" X 4-1/2" GALVANIZED 545 WHEEL
	9400103	ST205/75 BIAS PLY LOAD RANGE C TIRE ON A 14" X 5-1/2" GALVANIZED 545 WHEEL
RADIAL	9400315	ST175/80 RADIAL LOAD RANGE C TIRE ON A 13" X 4-1/2" GALVANIZED 545 WHEEL
	9400163	ST205/75 RADIAL LOAD RANGE C TIRE ON A 14" X 6" GALVANIZED 545 WHEEL

15" DIAMETER TIRE & WHEEL ASSEMBLIES

BIAS	9400104	ST205/75 BIAS PLY LOAD RANGE C TIRE ON A 15" X 5" GALVANIZED 545 WHEEL
	9400218	ST225/75 BIAS PLY LOAD RANGE D TIRE ON A 15" X 6" GALVANIZED SPOKE 655 WHEEL
RADIAL	9400216	ST205/75 RADIAL LOAD RANGE C TIRE ON A 15" X 5" GALVANIZED 545 WHEEL
	9400219	ST225/75 RADIAL LOAD RANGE D TIRE ON A 15" X 6" GALVANIZED SPOKE 655 WHEEL
	9400560	ST225/75 RADIAL LOAD RANGE D TIRE ON A 15" X 6" GALVANIZED MODULAR 655 WHEEL

16" DIAMETER TIRE & WHEEL ASSEMBLIES

RADIAL	9400739	ST225/75 RADIAL LOAD RANGE E TIRE ON A 16" X 6" GALVANIZED MODULAR 655 WHEEL
	9400642	ST225/75 RADIAL LOAD RANGE E TIRE ON A 16" X 6" GALVANIZED SPOKE 655 WHEEL
	9400226	ST235/80 RADIAL LOAD RANGE E TIRE ON A 16" X 6" GALVANIZED SPOKE 655 WHEEL
	9400221	ST235/80 RADIAL LOAD RANGE E TIRE ON A 16" X 6" GALVANIZED SPOKE 865 WHEEL
	9400557	ST235/85 RADIAL LOAD RANGE E TIRE ON A 16" X 6" GALVANIZED SPOKE 865 WHEEL
	9400576	ST235/85 RADIAL LOAD RANGE E TIRE ON A 16" X 6" GALVANIZED MODULAR 865 WHEEL
	9400424	ST235/85 RADIAL LOAD RANGE G TIRE ON A 16" X 6" GALVANIZED SPOKE 865 WHEEL
	9400589	ST235/85 RADIAL LOAD RANGE G TIRE ON A 16" X 6" GALVANIZED MODULAR 865 WHEEL

TIRE & WHEEL ASSEMBLIES

Aluminum Wheel & Tire Assemblies



•Pictured with T7 Sendel Wheels.



•S5



•S7



•S14



•T2



•T7

TIRE & WHEEL ASSEMBLIES

13" - 14" DIAMETER TIRE & WHEEL ASSEMBLIES

BIAS	9400312	ST175/80 BIAS PLY LOAD RANGE C TIRE ON A 13" X 5" SILVER ALUMINUM 545 HISPEC S7 WHEEL
	9400504	ST205/75 BIAS PLY LOAD RANGE C TIRE ON A 14" X 5.5" SILVER ALUMINUM 545 SENDEL T2 WHEEL
	9400472	ST205/75 BIAS PLY LOAD RANGE C TIRE ON A 14" X 5.5" SILVER ALUMINUM 545 HISPEC S5 WHEEL
RADIAL	9400253	ST205/75 BIAS PLY LOAD RANGE C TIRE ON A 14" X 5.5" BLACK ALUMINUM 545 HISPEC S7 WHEEL
	9400513	ST175/80 RADIAL LOAD RANGE C TIRE ON A 13" X 5.5" BLACK ALUMINUM 545 SENDEL T7 WHEEL
	9400505	ST205/75 RADIAL LOAD RANGE C TIRE ON A 14" X 5.5" SILVER ALUMINUM 545 SENDEL T2 WHEEL
	9400486	ST205/75 RADIAL LOAD RANGE C TIRE ON A 14" X 5.5" SILVER ALUMINUM 545 HISPEC S5 WHEEL
	9400512	ST205/75 RADIAL LOAD RANGE C TIRE ON A 14" X 5.5" BLACK ALUMINUM 545 SENDEL T7 WHEEL

15" DIAMETER TIRE & WHEEL ASSEMBLIES

BIAS	9400256	ST205/75 BIAS PLY LOAD RANGE C TIRE ON A 15" X 5" SILVER ALUMINUM 545 HISPEC S7 WHEEL
	9400270	ST225/75 BIAS PLY LOAD RANGE D TIRE ON A 15" X 6" SILVER ALUMINUM 655 SENDEL T7 WHEEL
	9400334	ST225/75 BIAS PLY LOAD RANGE D TIRE ON A 15" X 6" SILVER ALUMINUM 655 SENDEL T2 WHEEL
RADIAL	9400326	ST205/75 RADIAL LOAD RANGE C TIRE ON A 15" X 6" SILVER ALUMINUM 545 SENDEL T2 WHEEL
	9400328	ST205/75 RADIAL LOAD RANGE C TIRE ON A 15" X 6" BLACK ALUMINUM 545 SENDEL T7 WHEEL
	9400747	ST225/75 RADIAL LOAD RANGE D TIRE ON A 15" X 6" SILVER ALUMINUM 545 SENDEL T2 WHEEL
	9400388	ST225/75 RADIAL LOAD RANGE D TIRE ON A 15" X 6" BLACK ALUMINUM 545 SENDEL T7 WHEEL
	9400340	ST225/75 RADIAL LOAD RANGE D TIRE ON A 15" X 6" SILVER ALUMINUM 655 SENDEL T2 WHEEL
	9400342	ST225/75 RADIAL LOAD RANGE D TIRE ON A 15" X 6" BLACK ALUMINUM 655 SENDEL T7 WHEEL
	9400600	ST225/75 RADIAL LOAD RANGE E TIRE ON A 15" X 6" SILVER ALUMINUM 655 SENDEL T2 WHEEL
9400609	ST225/75 RADIAL LOAD RANGE E TIRE ON A 15" X 6" BLACK ALUMINUM 655 SENDEL T7 WHEEL	

15" DIAMETER TIRE & WHEEL ASSEMBLIES

RADIAL	9400464	ST235/80 RADIAL LOAD RANGE E TIRE ON A 16" X 6" BLACK ALUMINUM 655 HISPEC S14 WHEEL
	9400352	ST235/80 RADIAL LOAD RANGE E TIRE ON A 16" X 6" SILVER ALUMINUM 865 SENDEL T2 WHEEL
	9400354	ST235/80 RADIAL LOAD RANGE E TIRE ON A 16" X 6" BLACK ALUMINUM 865 SENDEL T7 WHEEL
	9400456	ST235/80 RADIAL LOAD RANGE E TIRE ON A 16" X 6.5" BLACK ALUMINUM 865 HISPEC S5 WHEEL
	9400413	ST235/85 RADIAL LOAD RANGE E TIRE ON A 16" X 6" SILVER ALUMINUM 865 SENDEL T2 WHEEL
	9400601	ST235/85 RADIAL LOAD RANGE G TIRE ON A 16" X 6" SILVER ALUMINUM 865 SENDEL T2 WHEEL
	9400763	ST235/85 RADIAL LOAD RANGE G TIRE ON A 16" X 6" BLACK ALUMINUM 865 SENDEL T7 WHEEL

TIRE & WHEEL ASSEMBLIES

PVD • Chrome Steel Wheel & Tire Assemblies

PVD



14" DIAMETER TIRE & WHEEL ASSEMBLIES

BIAS	9400726	ST205/75 BIAS PLY LOAD RANGE C TIRE ON A 14" X 5" SILVER-PVD MODULAR 545 WHEEL
	9400712	ST205/75 RADIAL LOAD RANGE C TIRE ON A 14" X 5" SILVER-PVD MODULAR 545 WHEEL

15" X 5" TIRE & WHEEL ASSEMBLIES

BIAS	9400682	ST205/75 BIAS PLY LOAD RANGE C TIRE ON A 15" X 5" SILVER-PVD MODULAR 545 WHEEL
	9400683	ST205/75 BIAS PLY LOAD RANGE C TIRE ON A 15" X 5" BLACK-PVD MODULAR 545 WHEEL
	9400949	ST205/75 BIAS PLY LOAD RANGE C TIRE ON A 15" X 5" SILVER-PVD MODULAR 550 WHEEL
	9400689	ST205/75 BIAS PLY LOAD RANGE C TIRE ON A 15" X 5" BLACK-PVD MODULAR 550 WHEEL
	9400687	ST205/75 BIAS PLY LOAD RANGE C TIRE ON A 15" X 5" SILVER-PVD MODULAR 655 WHEEL
RADIAL	9400688	ST205/75 BIAS PLY LOAD RANGE C TIRE ON A 15" X 5" BLACK-PVD MODULAR 655 WHEEL
	9400677	ST205/75 RADIAL LOAD RANGE C TIRE ON A 15" X 5" SILVER-PVD MODULAR 545 WHEEL
	9400676	ST205/75 RADIAL LOAD RANGE C TIRE ON A 15" X 5" BLACK-PVD MODULAR 545 WHEEL
	9400667	ST205/75 RADIAL LOAD RANGE C TIRE ON A 15" X 5" SILVER-PVD MODULAR 550 WHEEL
	9400674	ST205/75 RADIAL LOAD RANGE C TIRE ON A 15" X 5" BLACK-PVD MODULAR 550 WHEEL
	9400691	ST205/75 RADIAL LOAD RANGE C TIRE ON A 15" X 5" BLACK-PVD MODULAR 655 WHEEL
	9400692	ST205/75 RADIAL LOAD RANGE C TIRE ON A 15" X 5" SILVER-PVD MODULAR 655 WHEEL

15" X 6" TIRE & WHEEL ASSEMBLIES

BIAS	9400707	ST225/75 BIAS PLY LOAD RANGE D TIRE ON A 15" X 6" BLACK-PVD MODULAR 545 WHEEL
	9400710	ST225/75 BIAS PLY LOAD RANGE D TIRE ON A 15" X 6" BLACK-PVD MODULAR 550 WHEEL
	9400709	ST225/75 BIAS PLY LOAD RANGE D TIRE ON A 15" X 6" BLACK-PVD MODULAR 655 WHEEL
	9400706	ST225/75 BIAS PLY LOAD RANGE D TIRE ON A 15" X 6" SILVER-PVD MODULAR 545 WHEEL
	9400950	ST225/75 BIAS PLY LOAD RANGE D TIRE ON A 15" X 6" SILVER-PVD MODULAR 550 WHEEL
RADIAL	9400708	ST225/75 BIAS PLY LOAD RANGE D TIRE ON A 15" X 6" SILVER-PVD MODULAR 655 WHEEL
	9400639	ST225/75 RADIAL LOAD RANGE D TIRE ON A 15" X 6" SILVER-PVD MODULAR 545 WHEEL
	9400640	ST225/75 RADIAL LOAD RANGE D TIRE ON A 15" X 6" BLACK-PVD MODULAR 545 WHEEL
	9400733	ST225/75 RADIAL LOAD RANGE E TIRE ON A 15" X 6" SILVER-PVD MODULAR 545 WHEEL
	9400734	ST225/75 RADIAL LOAD RANGE E TIRE ON A 15" X 6" BLACK-PVD MODULAR 545 WHEEL
	9400956	ST225/75 RADIAL LOAD RANGE D TIRE ON A 15" X 6" SILVER-PVD MODULAR 550 WHEEL
	9400678	ST225/75 RADIAL LOAD RANGE D TIRE ON A 15" X 6" BLACK-PVD MODULAR 550 WHEEL
	9400742	ST225/75 RADIAL LOAD RANGE E TIRE ON A 15" X 6" SILVER-PVD MODULAR 550 WHEEL
	9400743	ST225/75 RADIAL LOAD RANGE E TIRE ON A 15" X 6" BLACK-PVD MODULAR 550 WHEEL
	9400693	ST225/75 RADIAL LOAD RANGE D TIRE ON A 15" X 6" SILVER-PVD MODULAR 655 WHEEL
	9400694	ST225/75 RADIAL LOAD RANGE D TIRE ON A 15" X 6" BLACK-PVD MODULAR 655 WHEEL
	9400740	ST225/75 RADIAL LOAD RANGE E TIRE ON A 15" X 6" SILVER-PVD MODULAR 655 WHEEL
9400661	ST225/75 RADIAL LOAD RANGE E TIRE ON A 15" X 6" BLACK-PVD MODULAR 655 WHEEL	

Benefits:

- Lighter than Chrome
- Does not pit or peel
- Will not oxidize, fade or discolor
- Environmentally friendly process

TIRE & WHEEL ASSEMBLIES



TIRE & WHEEL ACCESSORIES



•BEFORE

•AFTER



WHEEL CENTER CAPS

ITEM NO	ID NO	DESCRIPTION	FINISH	WHEEL PILOT
7600100	117EZ-60C	CENTER CAP WITH PLUG	CHROME	2.95
7600101	106EZ-60C	CENTER CAP WITH PLUG	CHROME	3.19
7600136	106EZB-60	CENTER CAP WITH PLUG	BLACK	3.19
7600108	106EZ-SS	CENTER CAP WITH PLUG	STAINLESS STEEL	3.19
7600102	102EZ-60C	CENTER CAP WITH PLUG	CHROME	3.28
7600112	120EZSS	CENTER CAP WITH PLUG	STAINLESS STEEL	3.28
7600095	107EZ-60C	CENTER CAP WITH PLUG	CHROME	3.75
7600137	107EZB	CENTER CAP WITH PLUG	BLACK	3.75
7600096	107EZSS	CENTER CAP WITH PLUG	STAINLESS STEEL	3.75
7600103	104EZ-60C	CENTER CAP WITH PLUG	CHROME	4.25
7600138	104EZB-60	CENTER CAP WITH PLUG	BLACK	4.25
7600109	104EZSS	CENTER CAP WITH PLUG	STAINLESS STEEL	4.25
7600104	105EZ-60C	CENTER CAP WITH PLUG	CHROME	4.82
7600110	105EZSS	CENTER CAP WITH PLUG	STAINLESS STEEL	4.82
7600105	112EZ-60C	CENTER CAP WITH PLUG	CHROME	5.12
7600111	112EZSS	CENTER CAP WITH PLUG	STAINLESS STEEL	5.12
7600106	-	REPLACEMENT CENTER CAP PLUG	BLACK	
7600107	-	REPLACEMENT CENTER CAP PLUG	CHROME	



1



2



3



4

WHEEL LINERS

REF NO	ITEM NO	ID NO	DESCRIPTION	FINISH	SIZE
1	7700044	1904	WHEEL NUT 60°	CHROME	1/2"-20
2	7700202	1904L	WHEEL NUT 60° 1.75" LONG	CHROME	1/2"-20
	7700201	1960LHD	WHEEL NUT 60°	CHROME	9/16"-18
	7700281	1954BK	WHEEL NUT 60°	BLACK	1/2"-20
3	7700282	1954BKL	WHEEL NUT 60° 1.75" LONG	BLACK	1/2"-20
	7700283	1690LBK	WHEEL NUT 60°	BLACK	9/16"-18
4	8200220	20405	LOCKING WHEEL NUT WITH 1 KEY	CHROME	1/2"-20

NOTE: NOT RECOMMENDED FOR USE IN SALT WATER.

SPARE TIRE MOUNTS



•8900001

•8900004

METAL WELD-ON SPARE MOUNT

ITEM NO	DESCRIPTION
8900001	ANGLED WELD-ON SPARE MOUNT KIT - RAW FINISH
8900004	STRAIGHT WELD-ON SPARE MOUNT KIT - RAW FINISH

NOTE: KITS INCLUDE SPARE MOUNT, BOLT, PUSHNUT, WASHER AND LUG NUT



ALUMINUM BOLT-ON SPARE TIRE MOUNT

REF NO	ITEM NO	DESCRIPTION
1	9250515	ALUMINUM SPARE TIRE MOUNT
	8900030	BOLT-ON SIDE MOUNT GALVANIZED SPARE TIRE MOUNT. BOLTS TO 4-1/2" - 6-1/2" BEAM 4-5-6 LUG WHEELS.
	8900031	BOLT-ON SIDE MOUNT GALVANIZED SPARE TIRE MOUNT. BOLTS TO 3" - 4" - 5" CHANNEL OR TUBE 4-5-6 LUG WHEELS.



2



3



4



5

ZINC PLATED BOLT-ON SPARE TIRE MOUNT

REF NO	ITEM NO	DESCRIPTION
2	8900002	BOLT-ON SIDE MOUNT ZINC PLATED SPARE TIRE MOUNT. BOLTS TO 3"W X 4"H CHANNEL OR TUBE 4-5 LUG WHEELS.
3	8900003	BOLT-ON SIDE MOUNT ZINC PLATED SPARE TIRE MOUNT. BOLTS TO 3"W X 5"H CHANNEL OR TUBE 4-5-6 LUG WHEELS.
4	8900009-01	U-BOLT SPARE MOUNT ZINC PLATED KIT 7/16"-20 DIAMETER. BOLTS TO 3" CHANNEL FOR 4-5 LUG WHEELS. LESS LOCK.
5	8900010-01	U-BOLT SPARE MOUNT ZINC PLATED KIT 7/16"-20 DIAMETER. BOLTS TO 3" CHANNEL FOR 4-5 LUG WHEELS. INCLUDES BRACKETS AND 1-1/2" WIDE LAMINATED STEEL BODY MASTERLOCK PADLOCK.

NOTE: MOUNTING HARDWARE INCLUDED WITH EACH KIT.



LOCKS FOR 1/2" LUG NUTS

ITEM NO	DESCRIPTION
8200220	LOCKING LUG NUT SET WITH KEY
8200224	SPARE TIRE LOCK WITH 2 KEYS

NOTE: NOT RECOMMENDED FOR USE IN SALT WATER.





FEATURES & BENEFITS

INDUSTRY LEADING ENDURANCE

- Lasted 10% Longer than Closest Competitor (Based on Independent Testing)

THICKER LINER THAN COMPETITION

- Maintains PSI
- Keeps Tire Cooler
- Maintains Structure
- Better Durability

DOUBLE STEEL BELTS

- Reinforces to Prevent Expanding and Contracting
- Counter Acts Heat Cycle Damage
- Improves Towing Stability Under Load

FULL NYLON CAP

- More Puncture Resistant
- Combats Heat Cycle Damage

10/32" TREAD DEPTH IS 25% DEEPER THAN MOST COMPETITORS

- Longer Lasting Tread
- Low rolling resistance reduces tread wear and improves fuel economy

HEAT-LESS COMPOUND TECHNOLOGY

- Slows Down Aging
- Extends Tire Life



GOODRIDE[®]

TIRE CONSTRUCTION

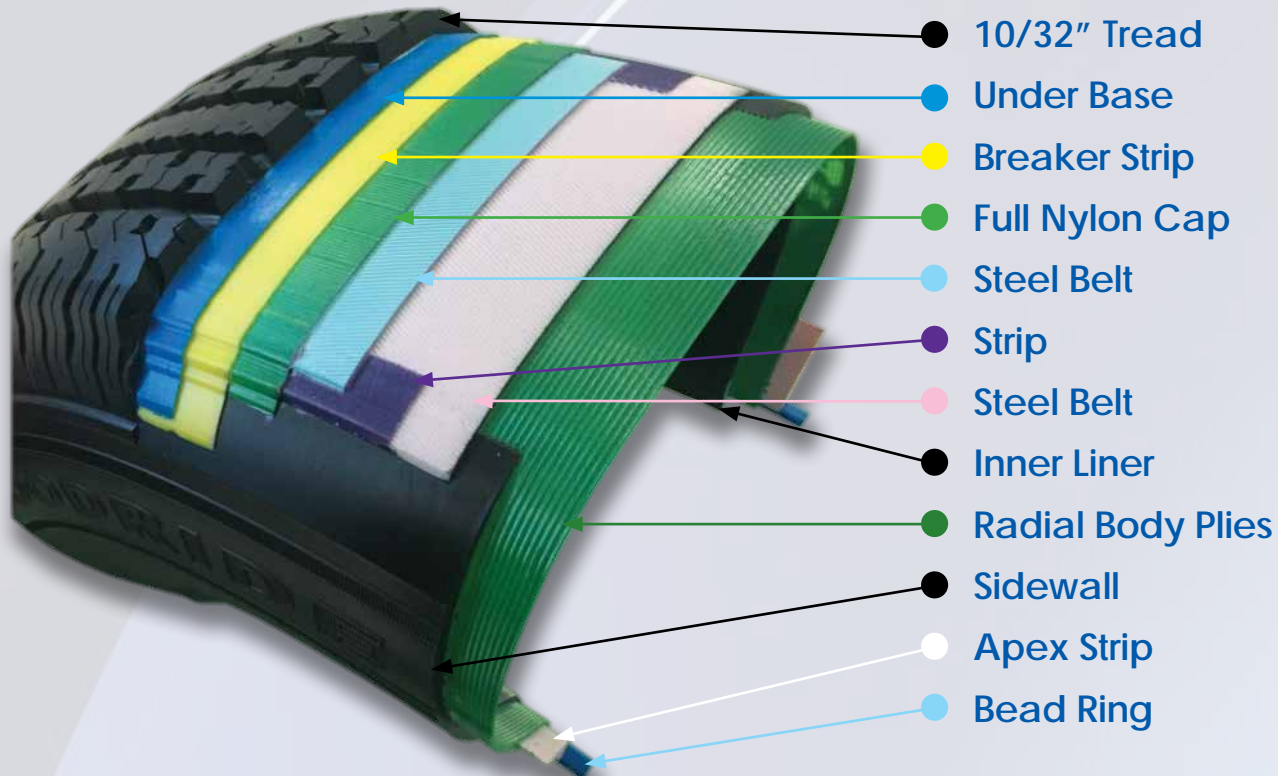

JACKS =



ZINC PLATED A-FRAME & SWIVEL MOUNT JACKS

REF NO	ITEM NO	DESCRIPTION	CAPACITY	CRANK	A	B	C
1	7950314	A-FRAME	3K	SIDE WIND			
2	7950518	SWIVEL MOUNT	1.5K	SIDE WIND	12.7"	22.7"	10.5"
3	7950266-TT	SWIVEL MOUNT	1.5K	SIDE WIND	12.7"	22.7"	12.5"
4	7950515-TT	SWIVEL MOUNT	1.2K	SIDE WIND	12.7"	22.7"	10.5"
5	7950232	SWIVEL MOUNT	1.6K	SIDE WIND	14.0"	24.0"	12.4"
6	7950231	SWIVEL MOUNT DUAL WHEEL	1.6K	SIDE WIND	14.0"	24.0"	12.4"
7	7950539	FIXED MOUNT DROPLEG	2.5K	SIDE WIND	7.0"	22.0"	18.5"
8	7950235	FIXED MOUNT	1.2K	SIDE WIND	9.3"	24.3"	19.5"



REPLACEMENT PARTS

REF NO	ITEM NO	DESCRIPTION
9	7950016	REPLACEMENT PIN FOR SWIVEL JACKS
10	7950096	REPLACEMENT HANDLE FOR SWIVEL JACKS (EXCEPT FULTON® SWIVEL JACKS)
11	7950366	REPLACEMENT TWIN CASTER SET FOR FULTON F2 JACKS
12	7950578	REPLACEMENT CASTER FOR FULTON F2 SINGLE WHEEL JACKS
13	7950243	REPLACEMENT CASTER 6" POLY BLACK



JACK ACCESSORIES

REF NO	ITEM NO	DESCRIPTION
14	7950244	FOOT WITH HARDWARE FOR 2K JACKS
15	7950508	FOOT WITH PIN LOCK FOR 2K JACKS
16	7950512	POLY CASTER 6" FOR 2" TUBE 1.2K CAPACITY
17	7950561	DROPLEG INSERT FOR MOST 2K-5K A-FRAME JACKS
18	7950247	JACK MOUNTING HARDWARE KIT
19	7950248	PLUNGER ASSEMBLY 1/2"
20	7950574	REPLACEMENT DROPLEG FOR 7K JACK
20	7950075	REPLACEMENT DROPLEG FOR 5K JACK



COUPLER ACCESSORIES

REF NO	ITEM NO	DESCRIPTION
21	6750098	COUPLER LATCH REPAIR KIT - 2" - RAM - TONGUE COUPLER
22	6750097	COUPLER LATCH REPAIR KIT - 2" - RAM - A-FRAME
23	6750281	EZ-LATCH® REPAIR KIT - 2-5/16" - DEMCO - ALL 2-5/16" BALL HITCHES
24	6750120	REPLACEMENT PIN FOR COLLAR LOCK TYPE COUPLER
25	6750119	REPLACEMENT COUPLER LATCH SAFETY PULL PIN WITH RING

EZ-LATCH COUPLERS

Demco

Demco
eZ-LATCH COUPLER

Demco's exclusive coupler design locks when dropped over its appropriate sized standard hitch ball.

The eZ-Latch coupler is offered in an array of different hitch mounts in both 2" and 2 5/16" ball coupler sizes.

Mounting configurations include:

- Weld on or bolt on 3" tongue tube
- Weld on or bolt on A-frame
- Bolt-on adjustable height channel mounts



Demco's eZ-Latch advantage ensures you get a safe, secure connection the first time, every time!

Make sure your coupler has the eZ-Latch advantage!



All Demco couplers conform to SAE J684 safety Standards without the use of any Safety Pin
Demco 2" and 2 5/16" eZ-Latch Couplers are Patent #76906732

COUPLERS =



ADJUSTABLE COUPLERS						
REF NO	ITEM NO	DESCRIPTION	FINISH	CAPACITY	BALL	SIZE
1	6750375	CAST EZ-LATCH ADJUSTABLE HEIGHT COUPLER, BLACK	PRIMED	21K*	2-5/16"	LESS CHANNEL BRACKET & HARDWARE
2	6750371	CAST EZ-LATCH ADJUSTABLE HEIGHT COUPLER, RED	PRIMED	21K*	2-5/16"	LESS CHANNEL BRACKET & HARDWARE
3	6750513	STAMPED ADJUSTABLE HEIGHT COUPLER - INCLUDES 6750132 BRACKET & HARDWARE	PAINTED	14K	2-5/16"	5-POSITION CHANNEL BRACKET & HARDWARE
4	6750346	STAMPED EZ-LATCH ADJUSTABLE HEIGHT COUPLER, BLACK	PRIMED	20K*	2-5/16"	LESS CHANNEL BRACKET & HARDWARE
5	6750374	STAMPED EZ-LATCH ADJUSTABLE HEIGHT COUPLER, RED	PRIMED	20K*	2-5/16"	LESS CHANNEL BRACKET & HARDWARE
6	6750563	STAMPED ADJUSTABLE HEIGHT COUPLER	PAINTED	14K	2-5/16"	WITH HARDWARE (LESS BRACKET)
7	6750242	STAMPED TRIGGER LATCH ADJUSTABLE HEIGHT COUPLER	ZINC	20K	2-5/16"	LESS CHANNEL BRACKET & HARDWARE
8	6750372	CAST ADJUSTABLE HEIGHT EZ-LATCH COUPLER	ZINC	21K	2-5/16"	LESS CHANNEL BRACKET & HARDWARE
9	6750131	WELD-ON CHANNEL BRACKET 3-POSITION 4-HOLE CHANNEL BRACKET FOR ADJUSTABLE COUPLERS 24K CAPACITY 0.312 X 7.5				
10	6750132	WELD-ON CHANNEL BRACKET 5-POSITION 6-HOLE CHANNEL BRACKET FOR ADJUSTABLE COUPLERS 24K CAPACITY 0.312 X 11.5				
11	7030001	GRADE 8 BOLT & NUT HARDWARE KIT FOR ADJUSTABLE HEIGHT & FLAT MOUNT COUPLERS 5/8" X 4.5" LONG (2-EA)				
	7030708	GRADE 5 MOUNTING BOLTS WITH LOCK NUTS & WASHERS FOR 20K & 21K CAPACITY ADJUSTABLE COUPLERS				

*Must use Demco hardware kit or equivalent to get full 20K or 21K capacity.



HINGE KIT FOR FOLD-AWAY COUPLER					
REF NO	ITEM NO	DESCRIPTION	FINISH	SIZE	CAPACITY
	6750222	BOLT-ON FOLD-AWAY COUPLER HINGE	ZINC	2" X 3"	5K
12	6750229	BOLT-ON FOLD-AWAY COUPLER HINGE	ZINC	3" X 3"	5K
	6750232	BOLT-ON FOLD-AWAY COUPLER HINGE	ZINC	3" X 4"	7.5K
13	6750216	WELD-ON FOLD-AWAY COUPLER HINGE	RAW	3" X 3"	5K

NOTE: MOUNTING HARDWARE IS INCLUDED WITH BOLT-ON HINGES



COUPLERS

COUPLERS =



1



2



3



4



5



6



7



8



9



10



11

ZINC PLATED COUPLERS

REF NO	ITEM NO	DESCRIPTION	CAPACITY	BALL	SIZE
1	6750521	STAMPED TRIGGER LATCH CHANNEL TONGUE COUPLER	2K	1-7/8"	FOR 2" CHANNEL TONGUE
2	6750558	STAMPED TRIGGER LATCH CHANNEL TONGUE COUPLER	2K	1-7/8"	FOR 2-1/2" CHANNEL TONGUE
3	6750523	STAMPED TRIGGER LATCH CHANNEL TONGUE COUPLER	3.5K	2"	FOR 2" CHANNEL TONGUE
4	6750562	STAMPED TRIGGER LATCH CHANNEL TONGUE COUPLER	3.5K	2"	FOR 2-1/2" CHANNEL TONGUE
5	6750527	STAMPED TRIGGER LATCH CHANNEL TONGUE COUPLER	3.5K	2"	FOR 3" CHANNEL TONGUE
6	6750529	STAMPED TRIGGER LATCH CHANNEL TONGUE COUPLER	5K	2"	FOR 3" CHANNEL TONGUE
7	6750417	STAMPED TRIGGER LATCH CHANNEL TONGUE COUPLER	5K	2"	FOR 3" CHANNEL TONGUE
8	6750381	STAMPED TRIGGER LATCH CHANNEL TONGUE COUPLER	10K	2"	FOR 3" CHANNEL TONGUE
9	6750409	STAMPED EZ-LATCH CHANNEL TONGUE COUPLER	10K	2"	FOR 3" CHANNEL TONGUE
10	6750394	STAMPED EZ-LATCH CHANNEL TONGUE COUPLER	18K	2-5/16"	FOR 3" CHANNEL TONGUE
11	6750218	STAMPED CHANNEL TONGUE COUPLER	21K	2-5/16"	FOR 3" CHANNEL TONGUE



PINTE EYES / HOOK & COMBINATION HITCH BALL ASSEMBLIES

REF NO	ITEM NO	DESCRIPTION	TYPE	DRAWBAR	CAPACITY	MOUNTING	NOTE	FINISH
1	8550099	PINTE EYE	ADJUSTABLE	3"	20K	2-BOLT MOUNT	LESS HARDWARE	ZINC
2	8550001	PINTE EYE	ADJUSTABLE	3"	24K	2-BOLT MOUNT	LESS HARDWARE	POWDER COATED
	8550029	PINTE HOOK - 2" TOW BALL COMBO	FLAT MOUNT USA	2.5" - 3"	16K / 10K	4-BOLT MOUNT	LESS HARDWARE	POWDER COATED
3	8550011	PINTE HOOK - 2-5/16" TOW BALL COMBO	FLAT MOUNT USA	2.5" - 3"	16K / 10K	4-BOLT MOUNT	LESS HARDWARE	POWDER COATED
4	8550042	PINTE HOOK - 2" TOW BALL COMBO	FLAT MOUNT IMPORT	2.5" - 3"	16K / 10K	4-BOLT MOUNT	LESS HARDWARE	POWDER COATED
	8550024	PINTE HOOK - 2-5/16" TOW BALL COMBO	FLAT MOUNT IMPORT	2.5" - 3"	16K / 10K	4-BOLT MOUNT	LESS HARDWARE	POWDER COATED
5	8550026	PINTE HITCH PLATE HARDWARE GRADE 8 (4-EACH BOLTS, NUTS & WASHERS) 1/2"-13 X 2"						



ALUMINUM HITCH BALL MOUNTS

REF NO	ITEM NO	DESCRIPTION	DROP	RISE	HOLE SIZE	CAPACITY	LENGTH	PIN SIZE
6	7350622	ALUMINUM BALL MOUNT	2"	1"	1"	14K	8-1/4"	5/8"
7	7350628	ALUMINUM SELF-LOCKING BALL MOUNT	2"	1"	1"	14K	8-1/4"	-
8	7350625	ALUMINUM BALL MOUNT	2"	1"	1-1/4"	14K	8-1/4"	5/8"
9	7350623	ALUMINUM BALL MOUNT	4"	3"	1"	14K	8-1/4"	5/8"
10	7350629	ALUMINUM SELF-LOCKING BALL MOUNT	4"	3"	1"	14K	8-1/4"	-
11	7350624	ALUMINUM BALL MOUNT	6"	5"	1"	14K	8-3/4"	5/8"



HITCH BALL MOUNT ASSEMBLIES

REF NO	ITEM NO	DESCRIPTION	DROP	BALL	TW	CAPACITY	LENGTH	PIN SIZE
12	7350583	HITCH BALL MOUNT ASSEMBLY W/ PIN	2"	2"	750	7.5K	8"	5/8"
13	7350685	HITCH BALL MOUNT ASSEMBLY W/ PIN	2"	2-5/16"	750	7.5K	8"	5/8"
14	7351302	HITCH BALL MOUNT ASSEMBLY W/ PIN	2"	2-5/16"	1,500	15K	8-1/2"	5/8"
15	7350584	HITCH BALL MOUNT ASSEMBLY W/ PIN	4"	2"	750	7.5K	8"	5/8"
16	7350585	HITCH BALL MOUNT ASSEMBLY W/ PIN	4"	2-5/16"	750	7.5K	8"	5/8"
17	7351303	HITCH BALL MOUNT ASSEMBLY W/ PIN	4"	2-5/16"	1,500	15K	8-1/2"	5/8"
18	7351419	HITCH BALL MOUNT ASSEMBLY W/ PIN	6"	2"	750	7.5K	8"	5/8"
	7351420	HITCH BALL MOUNT ASSEMBLY W/ PIN	6"	2-5/16"	1,500	15K	8-1/2"	5/8"

TOWING

TOWING



MULTI-HITCH BALL MOUNT ASSEMBLIES

REF NO	ITEM NO	DESCRIPTION	1-7/8"	2"	2-5/16"	LENGTH	PIN SIZE
1	7350188	DOUBLE BALL MOUNT ASSEMBLY SOLID SHANK FOR 2" RECEIVER	-	7.5K	10K	8-1/2"	5/8"
2	7350279	TRIPLE BALL MOUNT ASSEMBLY SOLID SHANK FOR 2" RECEIVER	5K	7.5K	10K	8-1/2"	5/8"



• MOST POPULAR!

• 7350391



• 7351752



Dual Lock Pack specifically designed for the Flash E-Series Ball Mount. The lock fits both 2" and 2.5" Tow Vehicle Receivers.

• 8200316



ALUMINUM HITCH BALL ASSEMBLIES • E SERIES PIN STYLE ADJUSTABLE HEIGHT

CHROME BALLS 2" & 2-5/16"		4" / 5" DROP / RISE	6" / 7" DROP / RISE	8" / 9" DROP / RISE	10" / 11" DROP / RISE	HIGH SECURITY HITCH LOCK KIT
2" SHANK	ITEM NO	7351752	7350391	7351750	7351751	ITEM NO
	ID NO	42-00-2400	42-00-2600	42-00-2800	42-00-2900	8200316
2-1/2" SHANK	ITEM NO	N/A	7351792	7351793	7351794	ID NO
	ID NO	N/A	42-00-2625	42-00-2825	42-00-2925	86-00-3660

N/A = NOT AVAILABLE



3



4



5



6

• OTHER OPTIONS AVAILABLE UPON REQUEST.



7



MULTI-HITCH BALL MOUNT ASSEMBLIES

ITEM NO	DESCRIPTION	SHANK	CAPACITY	DROP	RISE	BALL SIZE	FINISH	
7350388	ADJUSTABLE HITCH BALL MOUNT ASSEMBLY B&W TOW & STOW	2"	10K	5"	5-1/2"	1-7/8", 2" & 2-5/16"	POWDERCOAT	
3	7350255	ADJUSTABLE HITCH BALL MOUNT ASSEMBLY B&W TOW & STOW	2"	10K	5"	5-1/2"	2" & 2-5/16"	POWDERCOAT
7350379	ADJUSTABLE HITCH BALL MOUNT ASSEMBLY B&W TOW & STOW	2"	10K	7"	7-1/2"	1-7/8", 2" & 2-5/16"	POWDERCOAT	
4	7350251	ADJUSTABLE HITCH BALL MOUNT ASSEMBLY B&W TOW & STOW	2"	10K	7"	7-1/2"	2" & 2-5/16"	POWDERCOAT
5	7351650	ADJUSTABLE HITCH BALL MOUNT ASSEMBLY B&W TOW & STOW	2-1/2"	10K	5"	4-1/2"	2" & 2-5/16"	POWDERCOAT
7351652	ADJUSTABLE HITCH BALL MOUNT ASSEMBLY B&W TOW & STOW	2-1/2"	10K	7"	7-1/2"	2" & 2-5/16"	POWDERCOAT	
6	7350280	ADJUSTABLE HITCH BALL MOUNT ASSEMBLY B&W TOW & STOW	2"	10K	3"	3-1/2"	2" & 2-5/16"	CHROME
7	7350266	B&W REPLACEMENT PIN - STAINLESS STEEL WITH RETAINING PIN						

TOWING



RECEIVER HITCH PINS

REF NO	ITEM NO	DESCRIPTION
1	7350315	RECEIVER HITCH PIN 5/8" X 3" LONG WITH RETAINER CLIP ZINC
2	7350314	RECEIVER HITCH PIN 5/8" X 4" LONG WITH RETAINER CLIP ZINC
3	7350209	RECEIVER HITCH PIN 1/2" X 2-5/8" LONG WITH RETAINER CLIP
4	7350062	RETAINING CLIP ONLY FOR RECEIVER PINS - 5/32" X 3" ZINC
	7350210	PACKAGED - RECEIVER HITCH PIN 1/2" X 3-1/4" WITH CLIP



•RECEIVER TUBE

•ADAPTER SLEEVE



RECEIVER TUBES & ADAPTERS

ITEM NO	DESCRIPTION	SIZE	LENGTH
7350604	2-1/2" - 2" REDUCER SLEEVE KIT		CONVERTS 2" TO 2-1/2"
7351938	3" - 2" REDUCER SLEEVE KIT		CONVERTS 3" TO 2"
7350319	RECEIVER TUBE WITH 5/8" PIN HOLE	2" X 2" ID	6"
7350316	RECEIVER TUBE WITH 5/8" PIN HOLE	2" X 2" ID	12"
7350317	RECEIVER TUBE WITH 5/8" PIN HOLE	2" X 2" ID	18"
7350318	RECEIVER TUBE WITH 5/8" PIN HOLE	2" X 2" ID	24"
7350111	RECEIVER TUBE WITH 5/8" PIN HOLE	2" X 2" ID	36"



•STEP 1



•STEP 2



HITCHIN' ROD

ITEM NO	DESCRIPTION
7350274	HITCHIN' RODS - TWO RODS 4' LONG WITH MAGNETIC BASE



TOWING MIRROR

ITEM NO	DESCRIPTION
8850200	TOWING MIRROR

Durable all black mirror is fully adjustable to fit most standard OEM mirrors.





BETTER **BETTER**
LIGHTING **OPTIONS**
VALUE

You want it all:

the most advanced technology to ensure reliability, innovative designs to improve visibility and safety, and a lifetime warranty that guarantees you won't be left in the dark. You deserve better, and with Optronics that doesn't mean you have to pay more to get it.

8101370



www.optronicsinc.com

TOWING



HITCH BALLS						
REF NO	ITEM NO	A	B	C	CAPACITY	NOTE
1	6300026	1-7/8"	1"	2-1/8"	3.5K	CHROME
2	6300068	2"	3/4"	2-1/8"	3.5K	CHROME
3	6300070	2"	3/4"	3"	3.5K	CHROME
4	6300082	2"	1"	2-1/8"	7.5K	CHROME
5	6300081	2-5/16"	1"	3"	6K	CHROME
6	6300079	2-5/16"	1"	2-1/8"	7.5K	CHROME
7	6300191	2-5/16"	1"	2-1/4"	10K	CHROME
8	7350396	2-5/16"	1"	2-1/4"	12K	HT FORGED
9	6300031	2-5/16"	1-1/4"	2-1/8"	15K	CHROME
10	6300063	2-5/16"	1-1/4"	2-3/4"	30K	HT CHROME

NOTE: HT = HEAT TREATED

e2 ROUND BAR WEIGHT DISTRIBUTION & SWAY CONTROL HITCH		
ITEM NO	TW	CAPACITY
7351716	600	6,000
7351715	800	8,000
7351712	1,000	10,000



Benefits:

- Better Steering Control
- Better Braking Control
- More Comfortable Ride
- Much Higher Towing Capacity
- Less Wear & Stress on Tow Vehicle & Trailer
- Safer than Towing with a Ball Mount



LESS HASSLE • LESS STRESS • SAFER TOWING



FLASH

Every Flash™ ball mount is engineered, precision machined, and hand polished in America, using aircraft-grade aluminum. This means it will look and work great for years.

There is a Flash model to fit every need. Whether you tow multiple trailers, or just one, you won't find a faster, easier, or higher-quality ball mount that looks as great as the Flash.

E SERIES™

Adjustable Pin-style Ball Mount



The engineering, design, and craftsmanship of the E series™ is superior to any other pin-style ball mount on the market. Adjustments are quick and easy, making it effortless to switch between trailers and get on the road faster. Its gorgeous mirror finish will make heads turn every time you tow.

The Fastway Flash E series is the best looking pin-style ball mount you can buy. From stunning good looks to fast and easy adjustments, you'll be amazed every time you use it.

E series features:

- Fast and easy adjustments, saving you time and effort
- Polished aluminum, making your truck look its best
- Precision machined for strength and durability
- Aircraft-grade aluminum for corrosion resistance and outstanding performance
- Super strength alloy for years of safe towing
- 1,000 lb. max tongue wt. / 10,000 lb. max trailer wt.
- Limited One Year Warranty
- Made in the USA



E SERIES MODELS

Chrome Balls 2" & 2-5/16"		4" / 5" drop/rise	6" / 7" drop/rise	8" / 9" drop/rise	10" / 11" drop/rise
2" Shank	ITEM NO.	7351752	7350391	7351750	7351751
	ID NO.	42-00-2400	42-00-2600	42-00-2800	42-00-2900
2-1/2" Shank	ITEM NO.	n/a	7351792	7351793	7351794
	ID NO.	n/a	42-00-2625	42-00-2825	42-00-2925

n/a=not available

HIGH SECURITY KEYED-ALIKE LOCKING PIN AND HEIGHT ADJUSTMENT PIN PACK

ITEM NO.	8200316
ID NO.	86-00-3660



CARGO CONTROL



1



2



3



4



5

ZINC PLATED SAFETY CHAINS

REF NO	ITEM NO	DESCRIPTION
1	8850138	8/0 X 30" L GRADE 30 7.6K WITH 17/32" S-HOOK & LATCH
1	8850137	3/16" X 27" GRADE 30 3K 5.5MM HOOK & LATCH
1	8850128	3/16" X 27" GRADE 30 3.2K S-HOOK & LATCH
2	8850031	1/4" X 61" GRADE 30 5K 7/16" S-HOOK & LATCH
1	8850029	1/4" X 31" GRADE 30 5K 7/16" S-HOOK & LATCH
3	8850032	3/8" X 36" GRADE 43 16.2K FORGED HOOK & LATCH
4	8850025	3/8" X 39" GRADE 70 27.4K FORGED HOOK & LATCH
5	7350720	1/4" X 60" GRADE 30 5K HOOK & LATCH, BOXED 2-EA. CHAINS. VINYL COATING PROTECTS CHAINS FROM RUST.



6



7



9



6



7



8



9



10

RATCHET STRAPS

REF NO	ITEM NO	DESCRIPTION	SIZE	WLL	NOTE
6	9250172	TRANSOM RETRACTABLE TIE DOWN STRAP WITH S-HOOK	2" X 6'	3.5K	2-EACH INCLUDED
7	9250443	TRANSOM RATCHET STRAP W/ SNAP HOOK & PROTECTIVE SLEEVE	2" X 12'	3.5K	2-EACH INCLUDED
8	9250563	RETRACTABLE STRAP WITH S-HOOK	2" X 6'	1.1K	2-EACH INCLUDED
9	9250613	STAINLESS STEEL TRANSOM RETRACTABLE BOW TIE DOWN WITH 43-INCH STRAP AND S-HOOK	2" X 43"	1.5K	1-EACH INCLUDED
10	9250614	STAINLESS STEEL GUNWALE TIE DOWN	1" X 12'	0.3K	1-EACH INCLUDED



CARGO CONTROL

TONGUE BOXES | CLEANERS | SEALANT



1



2



TONGUE BOX

REF NO	ITEM NO	ID NO	DESCRIPTION
1	9450419	1701380	ALUMINUM TONGUE BOX 15"D X 14.5"H X 20"W (FRONT) 15"D X 14.5"H X 34"W (BACK)
2	9450115	1701680	POLY TONGUE BOX 19"D X 18"H X 18"W (FRONT) 19"D X 18"H X 36"W (BACK)

CLEANERS AND POLISHERS

REF NO	ITEM NO.	DESCRIPTION
3	6700052	<p>ALUMINUM BRIGHTNER & CLEANER 1-GALLON</p> <p>Safely removes road film, grime, algae, scum, lime deposits, water line stains, oxidation, and brightens bare aluminum. Works just like the traditional aluminum cleaner and brightener (Hydrofluoric Acid Brightener) WITHOUT the negative hazards associated with that product.</p>
4	6700050	<p>BLACK STREAK REMOVER 1-GALLON</p> <p>Removes black streaks that have set deep into the paint finish over time on campers, trailers and other equipment. After using the black streak remover, you can apply Ultra Guard product to protect the finish and stop streaks from setting in again.</p>
5	6750053	<p>ULTRA GUARD 1-GALLON</p> <p>Use Streak Master Ultra Guard as Wet Wash or Dry Wash. Dilute Ultra Guard to the desired dilution for any given job. Spray directly to the surface to be cleaned and wipe away grime and stains. With a dry towel, lightly buff to a brilliant clean and shine.</p>



3



4



5

SILICONE SEALANT

REF NO	ITEM NO.	DESCRIPTION
6	6700200	TREMPRO 644 RTV - ALUMINUM
	6700201	TREMPRO 644 RTV - WHITE
	6700202	TREMPRO 644 RTV - CLEAR
	6700203	TREMPRO 644 RTV - IVORY



6

AMERICAN METAL

DESIGNED & MADE IN THE USA BY BLAYLOCK



CARGO DOOR LOCK

Latch & Bolt Door Lock System

- Cargo, live stock & specialty trailers
- Latch & bolt lock system
- 040-DL-80 Cargo Door Lock \$Price

KING PIN COUPLER LOCK

- Fits 18 wheelers and the heaviest 5th wheel RVs
- Cast aluminum collar securely held in place with a hardened steel pin
- TL-70 King Pin Lock 8200069



EZ DISK LOCK

Padlock

- Bolt proof design makes access to stainless steel shackle with cutters virtually impossible
- Case is constructed of stainless steel with deep laser welded seams for high tensile strength
- Shackle is forged of hardened steel
- Imported
- TL-45 EZ Disk Lock 8200096



UNIVERSAL COUPLER RECEIVER LOCK

- For commercial and recreational use
- Fits over 30 different coupler style/brands
- Sizes 2-2 5/16"
- Covers brands & styles of receivers including Buyer's, Atwood, Fulton, U-Haul, Pro-Series, Titan, Atwood, Demco, to name a few
- TL-33 Universal Coupler Lock 8200090



BULLDOG COUPLER LOCK

- For commercial and recreational use
- Fits couplers 17/8-25/16"
- Fits Hammerblow, Bulldog & RAM
- Patented design ensures the most secure way to leave an unattended trailer
- Solid hardened steel lock rod for security
- TL-20 Bulldog Coupler Lock 8200053



WHEEL LOCK

Wheel Lock with Lugnut Lock

- For Trailer, RV, Automobile
- Visible wheel lock
- Fits wheels 13"-16" (EZ-300) or 15"-20" (EZ-302)
- Two Screw in locks with keys securely hold the arms in place
- Made from the highest quality Aircraft Grade Aluminum
- EZ-300 Wheel Lock-Medium 8200165



PINTLE DRAWBAR EYE COUPLER LOCK

- Industrial, Farm & Ranch, Heavy Machinery
- For tandem dump trucks, on-site generators, etc.
- Fits 2-1/2" to 3" eyes
- Patented design secure 2 cast aluminum disks with a solid steel locking pin
- TL-60 Pintle Drawbar Lock 8200057



GOOSENECK COUPLER LOCK

- For heavy trailers, livestock haulers, RV's
- Fits all gooseneck 2 5/16" style couplers (TL-50) and 2-5/16" RAM™ gooseneck style couplers (TL-55)
- Brands include Bulldog, T.E.M., TEMCO, Hammerblow/Cequent to name a few
- Patented design ensures the most secure way to leave an unattended trailer
- TL-50 2-5/16" 8200430
- TL-55 RAM™ 2-5/16" 8200430



GOOSENECK ADJUSTABLE SLEEVE LOCK

- For RV's, livestock haulers, heavy duty trailers
- All gooseneck style couplers
- Secures the adjustable sleeve locking the coupler in place
- Patented design ensures the most secure way to leave an unattended trailer
- Solid hardened steel lock rod for security
- TL-51 Adjustable Sleeve Lock 8200168



TOTAL ENCASEMENT BULLDOG COUPLER LOCK

- Recreational and industrial use
- Fits 2" (TL-22) and 2 5/16" (TL-23) bulldog style couplers
- One piece easy to use push button construction
- Covers hammerblow, cequent, bulldog
- Solid cast aluminum construction completely encases the receiver
- Hardened solid steel pin securely fastens lock over the coupler
- TL-22 2" 8200166
- TL-23 2-5/16" 8200166



LIP ENGAGING COUPLER LOCK

Push Button Lip Couplers

- For recreational trailer use
- Fits 2-5/16" couplers (TL-34), 2" couplers (TL-36), and 1 7/8 - 2" couplers (TL-38)
- Covers the following brands: Fulton, Feather Light, Ranger, most bumper pull RVs
- TL-38 Built-in Lock 1-7/8" 8200166

LOCKS =



RECEIVER LOCKS			
REF NO	ITEM NO.	ID NO.	DESCRIPTION
1	8200354	2866DAT	1/2" OR 5/8" CHROME, 3-5/8" LONG
2	8200350	1469DAT	5/8" 10K STAINLESS STEEL FITS 2.5" RECEIVER



BRAHMA[®]
Wheel Locks
 Tough stuff - No Bull



WHEEL LOCKS			
REF NO	ITEM NO	ID NO	DESCRIPTION
3	8200153	TWL100	WHEEL LOCK, 10" - 18" WHEEL
4	8200408	WL001*	WHEEL LOCK, 15" - 17" WHEEL
	8200484	WL002*	WHEEL LOCK, 13" - 14" WHEEL
	8200485	WL001A	BRAHMA WHEEL LOCK ALLOY / ALUMINUM WHEEL ADAPTER FOR USE WITH WL001/002

NOTE: WL001 OR WL002 REQUIRE WL001A FOR USE WITH ALLOY OR ALUMINUM WHEELS.



LOCKS =



5



6



7



8



9



10



11



12

COUPLER LOCKS

REF NO	ITEM NO	ID NO	DESCRIPTION
5	8200043	605DAT	3/4" SPAN TRIGGER STYLE COUPLER LOCK
6	8200102	377DAT	1-7/8" - 2" STAMPED COUPLER LOCK
7	8200158	86-00-5015	1-7/8" - 2-5/16" UNIVERSAL HIGH SECURITY LOCK
8	8200173	UMAX50	1-7/8" - 2-5/16" UNIVERSAL LOCK
9	8200362	2847DAT	9/16" - 2-3/4" SPAN COUPLER LOCK
10	8200367	1471DAT	3-1/2" SPAN COUPLER LOCK
11	8200365	RC4	2-1/2" SPAN COUPLER LOCK
11	8200366	RC5	3-3/8" SPAN COUPLER ACTUATOR LOCK
12	8200364	RC3	2-1/2" SPAN YOKE STYLE COUPLER LOCK



LED
LIFETIME
WARRANTY

OptrONICS

LED
Tail Lights



OE Replacements
& Upgrades

- Sealed, waterproof construction
- LED lighting is brighter, more reliable, and uses less energy
- Innovative product options available for every marine trailer

No-hassle
LIFETIME LED WARRANTY

LED Marker/
Clearance Lights



LED ID Light Bars



Waterproof performance
Guaranteed reliability

LED **LIFETIME**
WARRANTY

LIGHTING • PIPE-LIGHTS • CONSPICUITY TAPE

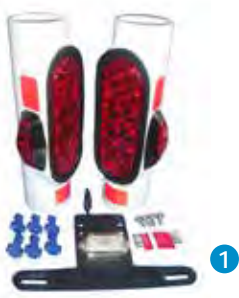

1



2



3



•DAY

•NIGHT

PIPE ADD-ON LIGHT KITS

REF NO	ITEM NO	ID NO	DESCRIPTION
1	8101598	1020	LED 10-DIODE PIPE ADD-ON LIGHT KIT WITH 10-FOOT LEADS AND MINI CLEARANCE MARKER LIGHTS, AND LICENSE PLATE BRACKET WITH LIGHT. REFLECTORS AND TERMINAL CONNECTORS INCLUDED.
2	8101582	1019	LED 10-DIODE PIPE ADD-ON LIGHT KIT WITH 10-FOOT LEADS
3	8101581	1018	INCANDESCENT PIPE ADD-ON LIGHT KIT WITH 10-FOOT LEADS

PIPE-LIGHT KITS

ITEM NO	ID NO	DESCRIPTION
8100960	27656A	LED LIGHT KIT FITS 2" PVC GUIDE-ON POST. WATERPROOF & SHOCKPROOF. AMBER FACES FRONT, RED FACES REAR. INCLUDES TWO SEALED ONE PIECE LED LAMPS, EACH WITH 8-FOOT LEADS, TERMINAL CONNECTORS AND POST LOCKING BOLTS.



4



5

ORDER YOUR CUSTOM LOGO TAPE TODAY!

- 20 roll minimum order
- No set-up fee
- 6"/6" or 7"/11" in kiss cut or continuous
- Ask a Sales Associate for details!

CONSPICUITY TAPE

REF NO	ITEM NO.	WARRANTY	DESCRIPTION
4	8100306	5-YEAR	6" RED / 6" WHITE PERFORATED ROLL 150'
	8100307	5-YEAR	6" RED / 6" WHITE CONTINUOUS ROLL 150'
	8100302	5-YEAR	7" WHITE / 11" RED PERFORATED ROLL 150'
	8101510	5-YEAR	7" WHITE / 11" RED CONTINUOUS ROLL 150'

PROMOTE YOUR COMPANY LOGO WITH YOUR OWN REFLECTIVE TAPE!

REF NO	ITEM NO.	WARRANTY	DESCRIPTION
5	8100306-XX	5-YEAR	6" RED / 6" WHITE PERFORATED ROLL 150'

NOTE: XX SIGNIFIES THE SUFFIX GIVEN TO THE ITEM NUMBER THAT WILL IDENTIFY THE TAPE AS YOUR LOGO TAPE.



No sparks.



NOTE: SEE OUR JUMP STARTERS ON PAGE 62.

LIGHTING • PIPE-LIGHTS • CONSPICUITY TAPE

LIGHTING • STOP | TURN | TAIL LIGHTS •



1



2



3

• CLEAR LENS RED DIODES



4



5



6

RED			6" OVAL SEALED GROMMET MOUNT		
REF NO.	ITEM NO.	KIT NO.	DIODES	SERIES	DESCRIPTION
1	8100627	8100627-02	6	STL12	LED "FLEET"
2	8100367	8100367-02	10	STL72	LED "PREMIUM"
3	8100662	-	10	STL82	LED "PREMIUM" CLR
4	8100939	-	22	STL111	LED "GLOLIGHT"
5	8100386	8100445	-	ST70	INCANDESCENT

NOTE: KIT INCLUDES LIGHT, GROMMET & PLUG.

RED			6" OVAL SEALED FLANGE MOUNT	
REF NO	ITEM NO.	ID NO.	DIODES	DESCRIPTION
6	8100651	STL73RB	6	LED "FLEET"
6	8100372	STL78RB	10	LED "PREMIUM"
	8100574	STL88RCB	10	LED "PREMIUM" CLR

NOTE: ALL 6" FLANGE MOUNT LIGHTS ARE HARD WIRED.



7



ACCESSORIES			
REF NO.	ITEM NO.	ID NO.	DESCRIPTION
7	8100387	A70GB	PVC GROMMET FOR 6" FLUSH MOUNT
8	8100388	A45PB	STRAIGHT PL-3 PIGTAIL 10"
9	8100403	A45CB	STRAIGHT 2-WIRE PIGTAIL 10"
10	8100532	A47PB	RIGHT ANGLE PL-3 PIGTAIL 10"
11	8100404	A49PB	RIGHT ANGLE 2-WIRE PIGTAIL 10"

LIGHTING • STOP | TURN | TAIL LIGHTS •



DRIVER SIDE • 7-FUNCTION		UNDER 80" STUD MOUNT			PASSENGER SIDE • 6-FUNCTION	
ITEM NO.	ID NO.	REF NO	DIODES	DESCRIPTION	ITEM NO.	ID NO.
8101083	STL009RB	1	3 / 2	LED "ONE"	8101082	STL008RB
8100369	STL9RB	2	14 / 11	LED "PREMIUM"	8100368	STL8RB
8100478	ST9RB	3	-	INCANDESCENT	8100477	ST8RB
8100766	ST7RB	4	-	SUBMERSIBLE	8100765	ST6RB



DRIVER SIDE • 7-FUNCTION		OVER 80" STUD MOUNT			PASSENGER SIDE • 6-FUNCTION	
ITEM NO.	ID NO.	REF NO.	DIODES	DESCRIPTION	ITEM NO.	ID NO.
8100366	STL3RB	5	14 / 11	LED "PREMIUM"	8100365	STL2RB
8100390	ST3RB	6	-	INCANDESCENT	8100389	ST2RB
8100191	ST5RB	7	-	SUBMERSIBLE	8100170	ST4RB



•8100565-02



•8100565-03

LED KIT	UNDER 80" STUD MOUNT LED KIT	LED KIT	UNDER 80" STUD MOUNT LED KIT
8100565-02	STUD MOUNT LIGHT KIT WITH LICENSE BRACKET & 25-FOOT WISHBONE HARNESS & STAINLESS STEEL MOUNTING HARDWARE. 21-DIODE 7-FUNCTION LIGHT WITH LICENSE PLATE LIGHT & 16-DIODE 6 FUNCTION LIGHT.	8100565-03	STUD MOUNT LIGHT KIT WITH LICENSE BRACKET & 25-FOOT WISHBONE HARNESS & STAINLESS STEEL MOUNTING HARDWARE.



•8101553



•8101554

LED KIT	UNDER 80" STUD MOUNT LED KIT	LED KIT	UNDER 80" STUD MOUNT LED KIT
8101553	STUD MOUNT LIGHT KIT WITH LICENSE BRACKET & 25-FOOT WISHBONE HARNESS & STAINLESS STEEL MOUNTING HARDWARE. 1-DIODE 7-FUNCTION LIGHT WITH LICENSE PLATE LIGHT & 1-DIODE 6 FUNCTION LIGHT - CLAM PACKAGED.	8101554	1-DIODE LED STUD MOUNT LIGHT KIT WITH LICENSE BRACKET & 25-FOOT WISHBONE HARNESS. 7-FUNCTION LIGHT WITH LICENSE PLATE LIGHT & 6 FUNCTION LIGHT. INCLUDES TWO AMBER STUD MOUNT SQUARE CLEARANCE MARKER LIGHTS.



• LIGHTING • STOP | TURN | TAIL LIGHTS

LIGHTING • STOP | TURN | TAIL LIGHTS •



1



2



3



4

ACCESSORIES

REF NO	ITEM NO	ID NO	DESCRIPTION
1	8100151	A8RB	REPLACEMENT LENS INCANDESCENT
2	8100481	AL8RB	REPLACEMENT LENS LED "PREMIUM"
3	8100156	A9RB	SIDE MARKER LIGHT LENS UNDER 80"
4	8100063	A2RB	SIDE MARKER LIGHT LENS OVER 80"
5	8100026	1157	BULB 12V BAYONET DUAL FILAMENTS
6	8100025	194	BULB 12V WEDGE
7	8100201	1895	BULB 14V .27 AMP 25 LUMENS



5



6



7



8



9

DRIVER SIDE/7-FUNCTION			RECTANGLE MARINE		PASSENGER SIDE/6-FUNCTION	
REF NO	ITEM NO	ID NO	DIODES	DESCRIPTION	ITEM NO	ID NO
8	8100518	STL17RB	22	LED "PREMIUM"	8100517	STL16RB
9	8100195	ST17RB	-	INCANDESCENT	8100196	ST16RB



10



11



12

DRIVER SIDE/7-FUNCTION			ROUND STT		PASSENGER SIDE/6-FUNCTION	
REF NO	ITEM NO	ID NO	DIODES	DESCRIPTION	ITEM NO	ID NO
10	8101378	ST15022	18	LED "PREMIUM"	8101377	ST15021
11	8100509	ST25RB	-	INCANDESCENT/STUD	8100520	ST24RB
12	8101405	ST21RS	-	INCANDESCENT/SURFACE	8101404	ST20RS

PEDESTAL MOUNT • STOP, TAIL & TURN

REF NO	ITEM NO	ID NO	DESCRIPTION
13	8100145	ST51RS	SINGLE FACE RED - STOP/TURN/TAIL
14	8100845	ST52RA	DUAL FACE AMBER / RED



13



14

LIGHTING • STOP | TURN | TAIL LIGHTS

LIGHTING • CLEARANCE MARKER LIGHTS •



CLEARANCE MARKER LIGHTS

RED		3/4" LED CLEARANCE / MARKER LIGHT			AMBER	
REF NO	ITEM NO	ID NO	DIODES	DESCRIPTION	ITEM NO	ID NO
1	8100625	MCL12RKB	1	LED CLEAR LENS COLORED DIODE	8100626	MCL12AKB
2	8100635	MCL11RKB	2	LED "PREMIUM" LIGHT	8100634	MCL11AKB
3	8100816	MCL11CRKB	2	LED "PREMIUM" CLEAR LENS LIGHT	8100815	MCL11CAKB
4	8101566	L14-0110R	2	LED "PREMIUM" LIGHT	8101565	L14-0110A



3/4" CLEARANCE MARKER LIGHT ACCESSORIES

REF NO	ITEM NO	ID NO	DESCRIPTION
5	8100902	A11GB	REPLACEMENT GROMMET FOR 3/4" LIGHTS
6	8101436	001187	*CHROME TRIM RING FOR 3/4" LIGHTS
7	9900356	21-151	HARNESS ADAPTER FOR 3/4" LIGHTS

*NOTE: INSTALLS OVER MOUNTING GROMMET, ADDING A HEAVY-DUTY AND SLEEK APPEARANCE. CORROSION RESISTANT.



RED		MINI SEALED			AMBER	
REF NO.	ITEM NO.	ID NO.	DIODES	DESCRIPTION	ITEM NO.	ID NO.
8	8100277	MCL13R2B	2	LED "PREMIUM"	8100278	MCL13A2B
9	8100511	MCL13CR2B	2	LED "PREMIUM" CLEAR	8100510	MCL13CA2B

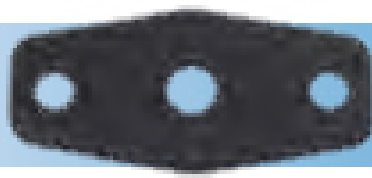
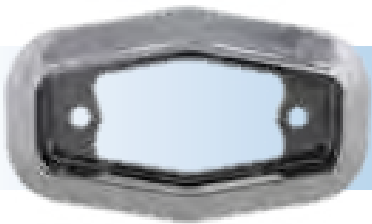

ACCESSORIES

REF NO.	ITEM NO.	ID NO.	DESCRIPTION
10	8100030	A13C2B	CHROME BASE / BEZEL
11	8100280	A13G2B	GASKET

10

11

LIGHTING • CLEARANCE MARKER LIGHTS



LIGHTING • CLEARANCE MARKER LIGHTS



RED			STUD MOUNT			AMBER	
REF NO	ITEM NO	ID NO	NO. WIRES	DIODES	DESCRIPTION	ITEM NO	ID NO
1	8100484	MCL36RB	2	6	LED REFLEX	8100359	MCL36AB
2	8100444	MC36RB	1	-	INCANDESCENT REFLEX	8100443	MC36AB
3	-	-	1	-	INCANDESCENT	8100379	MC37AB
4	8100921	-	1	-	INCANDESCENT	8100920	-

ACCESSORIES

REF NO	ITEM NO	ID NO	DESCRIPTION
5	8100025	194	BULB 12V WEDGE (EACH) BOX QTY 10

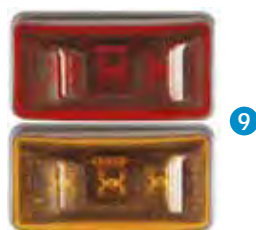

RED			SURFACE MOUNT			AMBER	
REF NO	ITEM NO	ID NO	DIODES	DESCRIPTION	NO. WIRE	ITEM NO	ID NO
6	8100601	MCL17RB	3	LED "MIRO-FLEX"	2	8100600	MCL17AB
7	8100637	MCL19CRB	4	LED "MIRO-FLEX" CLEAR LENS	2	8100636	MCL19CAB
8	8100376	MCL31RB	2	LED "PREMIUM"	2	8100375	MCL31AB
9	8100849	MCL95RB	3	LED "SEALED PREMIUM" MOUNT	1	8100848	MCL95AB
10	8100138	MC11RB	-	INCANDESCENT	1	8100139	MC11AB

LIGHTING • LIGHT BARS • BACK UP • LICENSE PLATE

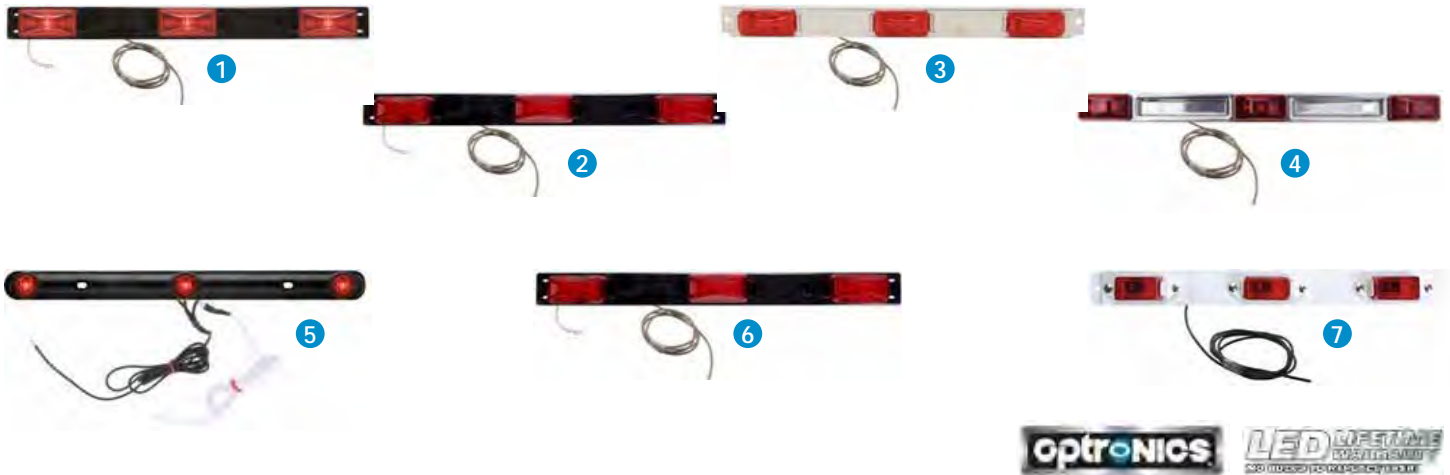

LIGHT BARS								
RED		SURFACE MOUNT LIGHT BARS						REPLACEMENT
REF NO	ITEM NO	ID NO	DIODES	DESCRIPTION	BASE	SIZE	MOUNTING	LIGHT / LENS
1	8100628	MCL83RB	3	LED "FLEET" SEALED 2-WIRE	POLYCARBONATE	15-15/16" X 1-15/16"	7-1/2"	8100593
2	8100363	MCL93RB	9	LED "PREMIUM" SEALED 2-WIRE	POLYCARBONATE	15-15/16" X 1-15/16"	7-1/2"	8100461
3	8100489	MCL84RB	9	LED "PREMIUM" SEALED 2-WIRE	STAINLESS STEEL	16-1/2" X 1-3/8"	16-1/16"	8100461
4	8100428	MCL97RB	9	LED "PREMIUM" SELF-GROUNDING	STAINLESS STEEL	14-1/4" X 1-3/16"	8-1/2"	-
5	8100887	MCL922RB	3	LED "PREMIUM" SEALED 2-WIRE	POLYCARBONATE	14-15/16" X 1-3/16"	8-1/2"	8100511
6	8100294	MC93RB	-	INCANDESCENT SEALED 2-WIRE	POLYCARBONATE	15-15/16" X 1-15/32"	7-1/2"	8100105
7	8100135	MC99RB	-	INCANDESCENT SELF-GROUNDING	STEEL / WHITE	15-1/16" X 1-3/8"	14-3/8"	8100141

LIGHTING • LIGHT BARS • BACK UP • LICENSE PLATE



BACK UP LIGHTS				
6" OVAL BACK UP LIGHT • DOT COMPLIANT				
REF NO	ITEM NO	ID NO	DIODES	DESCRIPTION
8	8101203	BUL111CB	22	LED DOT "GLOLIGHT"



6" OVAL FLANGE MOUNT BACK UP LIGHT • DOT COMPLIANT				
REF NO	ITEM NO	ID NO	DIODES	DESCRIPTION
9	8100373	BUL78CB	10	LED DOT "PREMIUM"



LICENSE PLATE LIGHTS & BRACKETS			
REF NO	ITEM NO	ID NO	DESCRIPTION
10	8100231	LP5SB	LICENSE PLATE HOLDER - BLACK ABS
11	8100384	B428-09	LICENSE PLATE HOLDER - ZINC





1



2



3



4



5



6



7

LED LIGHT BARS • WORK LIGHTS

REF NO	ITEM NO	ID NO	DIODES	DESCRIPTION	LENGTH	HEIGHT	OPTIONAL SIDE MOUNT BRACKETS
1	8101035	LB75	6	SINGLE ROW 18W 1350 LUMEN	7.87"	3.38"	8101174
2	8101177	LB77	18	SINGLE ROW 54W 4050 LUMEN	21.10"	3.38"	8101174
3	8101178	LB90	18	SINGLE ROW 90W 8100 LUMEN COMBO	30"	2.25"	-
4	8101230	LB78	6	DOUBLE ROW 18W 1350 LUMEN	4.57"	4.64"	8101174
5	8101179	LB79	12	DOUBLE ROW 36W 2700 LUMEN	7.87"	4.64"	8101174
6	8100846	54209-002	10	LED WORK LIGHT 10W 2025 LUMEN	4"	1"	
7	8100281	TL10CB	-	INCANDESCENT 12V ROUND	4.75"	2.9"	

LIGHT BRACKETS

REF NO	ITEM NO.	DESCRIPTION
8	8100747	ALUM BRACKET FOR STUD MOUNT LIGHT



8

ELECTRICAL =



1

2



3



4



5

6



7

8



9

10



11

12



13



14

15



16



17

18

TRAILER SIDE 7-WAY

REF NO	ITEM NO	ID NO	DESCRIPTION
1	7000087	12-706	PLASTIC 7-BLADE 12V 30-AMP, DUAL GRIP PLUG
2	9900055	20044	MOLDED CABLE 7-BLADE, DAUL GRIP PLUG 60" LONG

TRAILER SIDE 6-WAY

REF NO	ITEM NO	ID NO	DESCRIPTION
3	9900086	20034	MOLDED CABLE 6-PIN, DAUL GRIP PLUG 72" LONG

TRAILER SIDE 5-WAY

REF NO	ITEM NO	ID NO	DESCRIPTION	LENGTH
4	9900179	A30W5B	WISHBONE WIRING HARNESS WITH BRAKE & GROUND WIRES	40'
4	9900180	A40W5B	WISHBONE WIRING HARNESS WITH BRAKE & GROUND WIRES	30'

TRAILER SIDE 4-WAY

REF NO	ITEM NO	ID NO	DESCRIPTION	LENGTH
5	7000355	A20WB	HARNESS 4-FLAT WISHBONE	20'
5	9900071	A25WB	HARNESS 4-FLAT WISHBONE	25'
5	7000356	A30WB	HARNESS 4-FLAT WISHBONE	30'
5	7000353	A35WB	HARNESS 4-FLAT WISHBONE	35'
5	7000359	A40WB	HARNESS 4-FLAT WISHBONE WITH TUBING	42'
6	7001252	38112	ENDURANCE EASY-PULL 4-FLAT JACKETED WIRE PLUG	12"
7	7001253	38134	ENDURANCE EASY-PULL 4-FLAT JACKETED WIRE PLUG	48"
7	7001250-02	48114	ENDURANCE EASY-PULL 4-FLAT PLUG	12"
8	7001251	38132	ENDURANCE EASY-PULL 4-FLAT PLUG	48"
9	7001243	47004	EASY-PULL BOTH ENDS ENDURANCE™ 4-FLAT EXTENSION PLUG	24"
10	9900077	41836	HARNESS 4-FLAT	36"
11	7000039	48115	HARNESS 4-FLAT	12"
12	7000280	48125	HARNESS 4-FLAT WITH 3 SPLICE CONNECTORS	48"
13	7000102	47115	4-FLAT PLUG & SOCKET LOOP	48"
13	7000077	48145	4-FLAT PLUG & SOCKET LOOP	12"

TRAILER WIRE CONNECTION TESTER

REF NO	ITEM NO	ID NO	DESCRIPTION
14	7000009	12-741	7-WAY BLADE LED INDICATOR TESTER
15	7000008	12-410	4-WAY FLAT LED INDICATOR TESTER

WIRE LOOM

REF NO	ITEM NO	DESCRIPTION
16	7001060	1/4" SPLIT POLY WIRE LOOM - 100 FOOT ROLL
16	9900312	3/8" SPLIT POLY WIRE LOOM - 100 FOOT ROLL
16	9900311	1/2" SPLIT POLY WIRE LOOM - 100 FOOT ROLL
16	9900145	3/4" SPLIT POLY WIRE LOOM - 100 FOOT ROLL

CABLE ZIP TIES & ELECTRICAL TAPE

REF NO	ITEM NO	DESCRIPTION
17	7000287	100-EA 7.5" 50-LB BLACK CABLE ZIP TIES
17	7000311	100-EA 14.5" 50-LB BLACK CABLE ZIP TIES
18	7000265	3/4" ELECTRICAL TAPE 60-FOOT ROLL UL LISTED 176°

ELECTRICAL



VEHICLE SIDE 7-WAY			
REF NO	ITEM NO	ID NO	DESCRIPTION
1	7000088	12-707	PLASTIC 7-WAY BLADE ELECTRICAL SOCKET - HARDWIRE
2	7000049	40959	PLASTIC 7-WAY BLADE & 4-WAY FLAT ELECTRICAL SOCKET WITH OEM PLUG
3	7000797	40975	HD PLASTIC 7-WAY BLADE & 4-WAY FLAT ELECTRICAL SOCKET W/ OEM PLUG

VEHICLE SIDE 4-WAY

REF NO	ITEM NO	ID NO	DESCRIPTION
4	9900090	41837	HARNESS 4-WAY FLAT 36" LONG



ELECTRICAL ADAPTERS			
REF NO	ITEM NO	ID NO	DESCRIPTION
5	7000035	47185	4-WAY FLAT TO 7-WAY BLADE & 4-WAY FLAT
6	7000043	47205	4-WAY FLAT TO 7-WAY BLADE
7	7000041	12-716	7-WAY BLADE TO 4-WAY FLAT
8	7000334	12-744	7-WAY BLADE TO 5-WAY PIN
9	7000045	12-729	7-WAY BLADE TO 6-WAY PIN (AUXILIARY)

ELECTRICAL =



ProMar1 incorporates solid state and fully automatic technology that eliminates the need to use portable battery chargers for charging each battery on-board one at a time. The compact design is lightweight and pre-wired for quick and easy installation. Mount it, plug it in and forget about it. Epoxy Filled 100 Percent Waterproof and Shockproof Design. 2-Year Warranty.

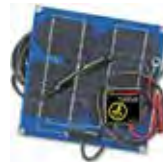

BATTERY & ACCESSORIES		
REF NO	ITEM NO	DESCRIPTION
1	7001356	BATTERY CHARGER .750-AMP 12V
2	6900198	BATTERY CHARGER 5-AMP 12V PROMAR
	6900469	BATTERY CHARGER 5-AMP 12V W/PLUG COVER
3	6250014	BATTERY 685-AMP 12V DEEP CYCLE 550-CCA
4	7000925	BATTERY CABLE - RED 4GA 49" LONG
5	7000926	BATTERY CABLE - BLACK 4GA 49" LONG
6	6900003	BATTERY BOX WITH STRAP
7	6250004	12V SOLAR CHARGER 2W MAINTAINER
8	6250005	12V SOLAR CHARGER 5W MAINTAINER
9	7001354	12V SOLAR CHARGER 5W MAINTAINER
10	7001351	EYELET TERMINAL CONNECTOR FOR 7001354
11	6250003	EXTREME CHARGE 12V BATTERY DESULFATOR
12	7001347	GB40 JUMP STARTER/ACCY CHARGER 1000A 2.1A USB
13	7001348	GB70 JUMP STARTER/ACCY CHARGER 2000A 2.1A USB
14	7001355	GEN2 20 AMP 2 BANK BATTERY CHARGER
15	7001358	GEN4 40 AMP 4 BANK BATTERY CHARGER
16	7001357	GCP1 110V PLUG HOUSING WITH 16" CORD

*SEE NOCO AD PAGE 108



BREAKAWAY KITS =



PREWIRED BREAKAWAY KITS WITH CHARGER

REF NO	ITEM NO	ID NO	AXLES	TYPE	LED TEST	ELEC/HYD	BATTERY	REPLACEMENT	
								BATTERY	SWITCH
1	6550020	2343	1-2	FRONT	NO	NO	5 AMP	6250009	6550019
2	6550021	2382	1-2	FRONT	YES	NO	5 AMP	6250009	6550019
3	6550036	50-85-312	1-3	TOP	NO	NO	5 AMP	6250009	6550019
4	6550028	034-285-00	1-4	TOP	NO	YES	9 AMP	6250009	6550019



NOTE: ZIP CABLE DOES NOT INCLUDE A BREAKAWAY PIN.

BREAKAWAY PIN & CABLE ASSEMBLIES

REF NO	ITEM NO	ID NO	DESCRIPTION
5	6550039	80-01-2140	UNIVERSAL ZIP CABLE 4' LONG & LATCH
5	6550052	80-01-2160	UNIVERSAL ZIP CABLE 6' LONG & LATCH
6	6550011	2348	REPLACEMENT PIN & CABLE FOR 6550010
7	6550016	2350	REPLACEMENT PIN & CABLE FOR 6550019



BREAKAWAY SWITCHES WITH PIN AND 4' LEAD / CABLE

REF NO	ITEM NO	DESCRIPTION
8	6550019	BREAKAWAY SWITCH & PIN
9	6550010	TEKONSHA 2010 BREAKAWAY SWITCH & PIN



REPLACEMENT BATTERIES

REF NO	ITEM NO	DESCRIPTION
10	6250009	12V 5 AMP BREAKAWAY BATTERY
11	6251270	12V 8 AMP BREAKAWAY BATTERY
12	6550003	12V DC BATTERY CHARGER
13	6250007	12V DC TEKONSHA BATTERY CHARGER
14	6500027	2-STAGE 12V DC TEKONSHA CHARGER



BREAKAWAY KITS

BRAKE CONTROLS =



BRAKE CONTROLLERS						
REF NO	ITEM NO	ID NO	DESCRIPTION	TYPE	LEVELING	
1	6500064	51120	DISCOVERY BRAKE CONTROLLER FOR 1, 2, 3 & 4 AXLES	TIMED	AUTO	
2	6500017	9030	VOYAGER BRAKE CONTROLLER FOR 1, 2, 3 & 4 AXLES	PROPORTIONAL	MANUAL	



BRAKE CONTROL HARNESSES					
REF NO	ITEM NO	ID NO	DESCRIPTION	TYPE	
3	6500106	51120	CURT HARNESS FOR GM TRUCKS AND MOST SUVS	2014-2017	
3	6500153	3016-P	TEKONSHA HARNESS FOR GM TRUCKS AND MOST SUVS	2014-2017	
4	6500075	51433	CURT HARNESS FOR FORD EXPEDITION	2013-2017	
4	6500051	3034-P	TEKONSHA HARNESS FOR FORD EXPEDITION	2013-2017	
5	6500152	51458	CURT HARNESS FOR RAM 3500	2015-2016	
5	6500141	3024-P	TEKONSHA HARNESS FOR RAM 3500	2015-2016	
6	6500140	51456	CURT HARNESS FOR TOYOTA TUNDRA	2015-2016	
6	6500146	3017-P	TEKONSHA HARNESS FOR TOYOTA TUNDRA	2015-2016	

NOTE: MORE HARNESSES ARE AVAILABLE FOR OTHER MAKES AND MODELS. CONTACT YOUR SALES REPRESENTATIVE.

BRAKE CONTROLS



BRAKE ACTUATORS • 6,000 LB. CAPACITY •

BRAKE ACTUATOR 6K 1-7/8" AND 2" COUPLER

6,000 pound capacity, maximum GVWR, 600 pound tongue load. GVWR limited to ball rating.
 NOTE: For 3" wide trailer tongue. Fits 1-7/8", 50mm and 2" ball (some adjustments required).
 Zinc Plated unless otherwise stated.



ITEM NO	BRAKE TYPE
9050055	DRUM
9050068	DISC

•PARTS BREAKDOWN PAGE 71

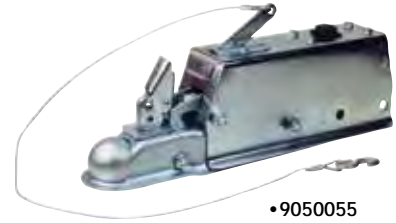

•9050055



ITEM NO	BRAKE TYPE
9050161	DRUM

•PARTS BREAKDOWN PAGE 72



•9050161



ITEM NO	BRAKE TYPE
9050177	DRUM
9050213	DISC

NOTE: FOR 3" WIDE TRAILER TONGUE.
 FITS 2" BALL.

•PARTS BREAKDOWN PAGE 74-75

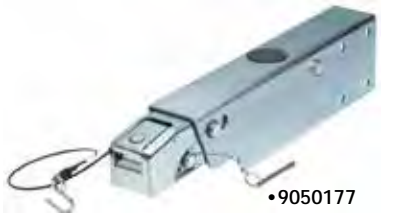

•9050177

BRAKE ACTUATOR 6.6K 1-7/8" AND 2" COUPLER

6,600 pound capacity, maximum GVWR, 660 pound tongue load. GVWR limited to ball rating.
 NOTE: For 3" wide trailer tongue. Fits 2" ball.



ITEM NO	BRAKE TYPE
9050259	DRUM
9050258	DISC

•PARTS BREAKDOWN PAGE 76-77



•9050258

BRAKE ACTUATORS • 7,000 LB. CAPACITY •

BRAKE ACTUATOR 7K 1-7/8" AND 2" COUPLER

7,000 pound capacity, maximum GVWR, 700 pound tongue load. GVWR limited to ball rating.
 NOTE: For 3" wide trailer tongue. Fits 1-7/8", 50mm and 2" ball (some adjustments required).
 Zinc Plated.



ITEM NO	BRAKE TYPE
9050175	DISC

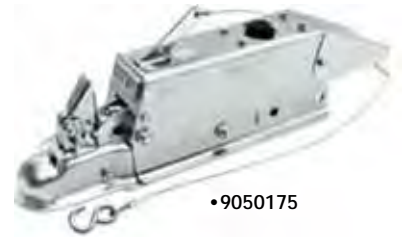

•9050175

BRAKE ACTUATOR 7.5K 1-7/8" AND 2" COUPLER

7,500 pound capacity, maximum GVWR, 750 pound tongue load. GVWR limited to ball rating.
 NOTE: For 3" wide trailer tongue.
 Zinc Plated.



ITEM NO	BRAKE TYPE
9050214	DRUM
9050206	DISC

•PARTS BREAKDOWN PAGE 74-75



•9050214



ITEM NO	BRAKE TYPE
9050261	DRUM
9050260	DISC

•PARTS BREAKDOWN PAGE 78



•9050258

• BRAKE ACTUATORS • 7,000 LB. CAPACITY



BRAKE ACTUATORS • 8,000 LB. CAPACITY •

BRAKE ACTUATOR 8K

8,000 pound capacity, maximum GVWR, 800 pound tongue load. GVWR limited to ball rating.
NOTE: For 3" wide trailer tongue.

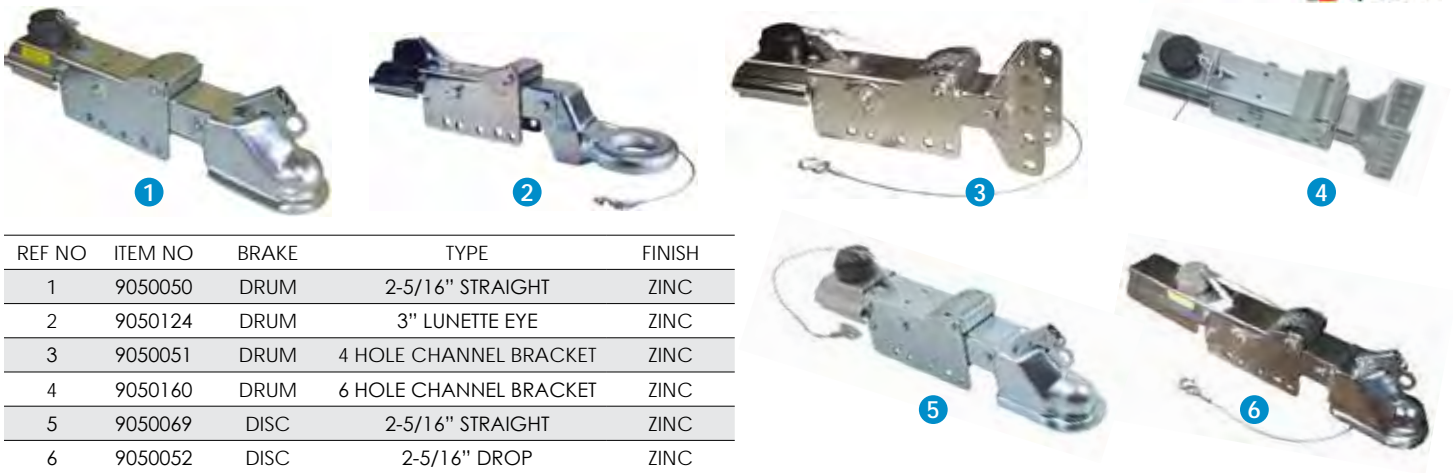

REF NO	ITEM NO	BRAKE	TYPE	FINISH
1	9050050	DRUM	2-5/16" STRAIGHT	ZINC
2	9050124	DRUM	3" LUNETTE EYE	ZINC
3	9050051	DRUM	4 HOLE CHANNEL BRACKET	ZINC
4	9050160	DRUM	6 HOLE CHANNEL BRACKET	ZINC
5	9050069	DISC	2-5/16" STRAIGHT	ZINC
6	9050052	DISC	2-5/16" DROP	ZINC

•PARTS BREAKDOWN PAGE 79



REF NO	ITEM NO	BRAKE	TYPE	FINISH	MOUNT
7	9050111	DRUM	4 HOLE CHANNEL BRACKET	PRIMED	BOLT-ON 3-HOLE STANDARD
8	8759132	DRUM	4 HOLE DROP CHANNEL BRACKET	ZINC	BOLT-ON 3-HOLE STANDARD
9	9050194	DRUM	FLAT MOUNT	PRIMED	BOLT-ON 3-HOLE STANDARD
10	9050083	DISC	2-5/16" EASY LATCH COUPLER	ZINC	BOLT-ON 5-HOLE STANDARD

•PARTS BREAKDOWN PAGE 80

BRAKE ACTUATOR 8.4K 2-5/16"

8,400 pound capacity, maximum GVWR, 840 pound tongue load. GVWR limited to ball rating.
NOTE: For 3" wide trailer tongue.



REF NO	ITEM NO	BRAKE TYPE
11	9050216	DRUM
12	9050217	DISC

•PARTS BREAKDOWN PAGE 75



• BRAKE ACTUATORS • 8,000 LB. CAPACITY

BRAKE ACTUATORS • 12,500 LB. CAPACITY •

BRAKE ACTUATOR 12.5K

12,500 pound capacity, maximum GVWR, 1,200 pound tongue load. GVWR limited to ball rating.
NOTE: Actuator capacity is degraded to the lowest component capacity rating.

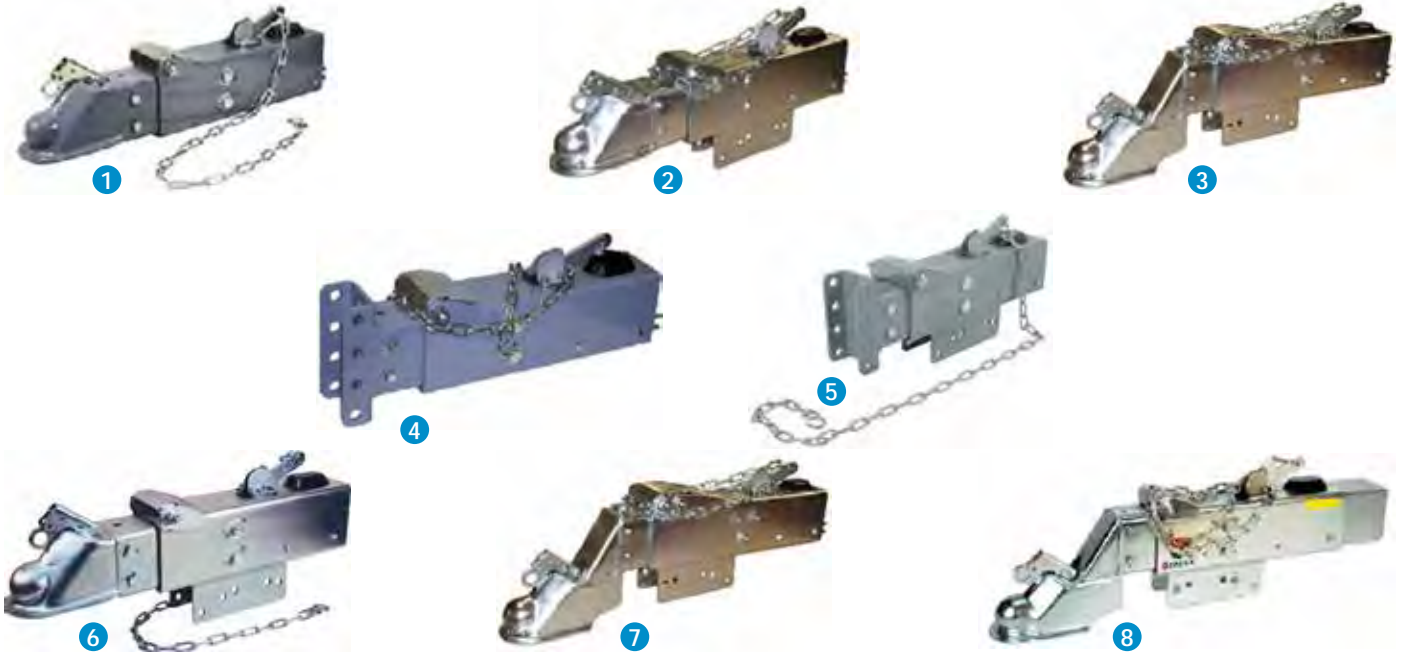

REF NO	ITEM NO	BRAKE	TYPE	FINISH	ATTACH
1	9050047	DRUM	2-5/16" STRAIGHT	PAINTED	WELD-ON
2	9050203	DRUM	2-5/16" 2.5" OFFSET	ZINC	1/2" BOLT-ON
3	9050085	DRUM	2-5/16" DROP	ZINC	5/8" BOLT-ON
4	9050046	DRUM	4-HOLE CHANNEL	PAINTED	WELD-ON
5	9050181	DRUM	4-HOLE CHANNEL, 2.5" OFFSET	PAINTED	1/2" BOLT-ON
6	9050071	DISC	2-5/16" 2.5" OFFSET	ZINC	1/2" BOLT-ON
7	9050070	DISC	2-5/16" DROP	ZINC	5/8" BOLT-ON
8	9050066	DISC	2-5/16" DROP	ZINC	5/8" BOLT-ON

•PARTS BREAKDOWN PAGE 82-83

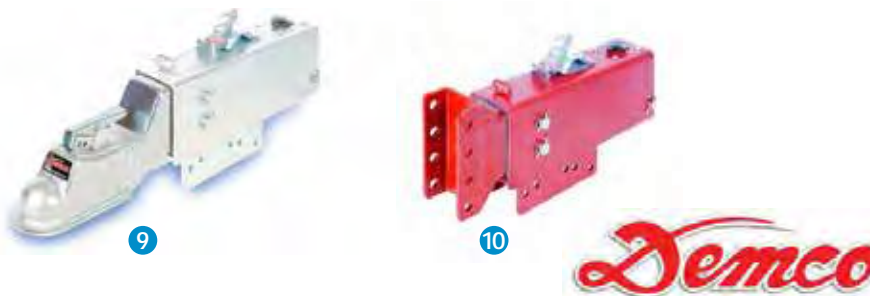

REF NO	ITEM NO	BRAKE	TYPE	FINISH	ATTACH
9	9050144	DISC	2-5/16" EASY LATCH COUPLER	PAINTED	WELD-ON
10	9050252	DRUM	STRAIGHT 8" 4-BOLT CHANNEL	PAINTED	BOLT-ON 5-HOLE

•PARTS BREAKDOWN PAGE 84

• BRAKE ACTUATORS • 12,500 LB. CAPACITY



BRAKE ACTUATORS • 16,000 LB. CAPACITY •

BRAKE ACTUATOR 16K

16,500 pound capacity, maximum GVWR, 1,650 pound tongue load. GVWR limited to ball rating.
NOTE: For 3" wide trailer tongue.



REF NO	ITEM NO	BRAKE	TYPE	FINISH
1	099-160-05	DRUM	2-5/16" A-160 STRAIGHT D-BRACKET	ZINC
2	099-162-05	DRUM	2-5/16" A-160 DROP D-BRACKET	ZINC
	099-160-25	DISC	2-5/16" A-160 STRAIGHT D-BRACKET	ZINC
	099-162-25	DISC	2-5/16" A-160 DROP D-BRACKET	ZINC

•PARTS BREAKDOWN PAGE 85



REF NO	ITEM NO	BRAKE	TYPE	FINISH
3	9050263	DRUM	2-5/16" MODEL 165 RAPTOR	ZINC
4	9050254	DISC	2-5/16" MODEL 165 RAPTOR	ZINC

BRAKE ACTUATORS • 20,000 LB. CAPACITY •

BRAKE ACTUATOR 20K

20,000 pound capacity, maximum GVWR, 2,000 pound tongue load. GVWR limited to ball rating.
NOTE: Actuator capacity is degraded to the lowest component capacity rating.



REF NO	ITEM NO	BRAKE	TYPE	FINISH	ATTACH
1	9050133	DRUM	2-5/16" STRAIGHT	ZINC	BOLT-ON
2	9050074	DRUM	2-5/16" DROP	ZINC	BOLT-ON
3	9050158	DISC	2-5/16" STRAIGHT	ZINC	BOLT-ON
4	9050067	DISC	2-5/16" DROP	ZINC	BOLT-ON

•PARTS BREAKDOWN PAGE 86-87



REF NO	ITEM NO	BRAKE	TYPE	FINISH	ATTACH
5	9050089	DRUM	2-5/16" EASY LATCH COUPLER	ZINC	BOLT-ON 5-HOLE
6	8204311	DISC	2-5/16" EASY LATCH COUPLER	ZINC	BOLT-ON 5-HOLE

•PARTS BREAKDOWN PAGE 88

• BRAKE ACTUATORS • 20,000 LB. CAPACITY



ACTUATOR COUPLERS • 6,000 LB. - 7,000 LB. CAPACITY •

BRAKE ACTUATOR 6K & 7K 1-7/8" & 2" COUPLER

6,000 Pound Capacity, Maximum Gvwr, 600 Pound Tongue Load. Gvwr Limited To Ball Rating.
NOTE: For 3" Wide Trailer Tongue. Fits 1-7/8", 50Mm And 2" Ball (Some Adjustments Required).

ITEM NO	BRAKE TYPE	MASTER CYLINDER	MASTER CYLINDER ASSEMBLY	COUPLER REPAIR KIT	CAPACITY
9050055	DRUM	9050013	9050094	6750082	6,000
9050068	DISC	4714200042	9050062	6750082	6,000
9050175	DISC	4714200042	9050062	6750082	7,000

MODEL 60 ACTUATOR DIAGRAM



18 - Master Cylinder Kit



19 - Leverlock Parts



20 - Master Cylinder Repair Kit



MODEL 60 LEVERLOCK PLATED ACTUATOR

REF NO	ITEM NO	DESCRIPTION	QTY
1	6750307	COUPLER CASE	1
2	4863800	OUTER CASE	1
3	2337700	STRUT	1
4	48358500183	SOLENOID VALVE COVER	1
5	2339100	LOCKNUT, HEX 7/16" NF	1
6	2339000	BOLT, HEX 7/16" NF	1
7	9050021	SHOCK ABSORBER	1
8	2327800	ROLLER	4
9	4861300	BOLT, HEX 1/2" NF	2
10	4861400	LOCKNUT, HEX 1/2" NF	2
11	2452500183	PLATED FRONT COVER	2
12	6450624	SOLENOID BACKUP VALVE	1
13	9050178	BREAKAWAY ASSEMBLY	1
14	9050113	S-HOOK (INCLUDED W/ #13)	1
15	9050241	PUSH ROD ASSEMBLY	1
16	4005200	BREAKAWAY SPRING	1
17	4861200	COVER SCREW	6
18	9050094	MASTER CYLINDER KIT	1
DRUM BRAKES 1.25" BORE CONSISTING OF 18A - 18G:			
18	9050062	MASTER CYLINDER KIT	1
DISC BRAKES 1.25" BORE CONSISTING OF:			
18A	9050093	FILLER CAP	1
18B	9050249	GASKET	1
18C	2356600	MASTER CYLINDER COVER	1
18D	9050013	MASTER CYLINDER - DRUM	1
	4714200042	MASTER CYLINDER - DISC	1
18E	9050116	CONNECTOR FITTING - DRUM	1
	4750300	CONNECTOR FITTING - DISC	1
18F	0794000	LOCKWASHER 1/4"	4
18G	1050800	BOLT HEX 1/4" NC	4
19	6750082	LEVERLOCK COUPLER KIT	1
LEVERLOCK COUPLER REPAIR KIT CONSIST OF:			
19A	4358500	HANDLE ASSEMBLY	1
19B	4336800	SPRING	1
19C	4335800	BALL LATCH	1
19D	4334500	SPRING PLATE	1
19E	1809000	LOCK PLATE	1
19F	4861400	LOCKNUT, HEX 1/2" NF	1
20	1502600	MASTER CYLINDER REPAIR KIT WAGNER 1" BORE	1
21	4360900	QR PIN & LANYARD ASSY	1

Individual Components Are Special Order Parts Only.

ACTUATOR COUPLERS • 6,000 LB. - 7,000 LB. CAPACITY

ACTUATOR COUPLERS • 6,000 LB. CAPACITY •

BRAKE ACTUATOR 6K 1-7/8" & 2" COUPLER

6,000 Pound Capacity, Maximum Gvwr, 600 Pound Tongue Load. Gvwr Limited To Ball Rating.
NOTE: For 3" Wide Trailer Tongue. Fits 1-7/8", 50mm And 2" Ball (Some Adjustments Required).



Do not adjust these bolts. They are factory torqued and must remain loose enough to allow free coupler movement.

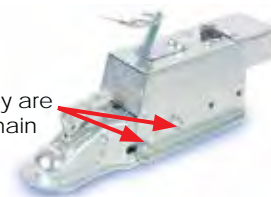

ITEM NO	BRAKE TYPE	MASTER CYLINDER
9050161	DRUM	9050031
8605101	DISC	9050091

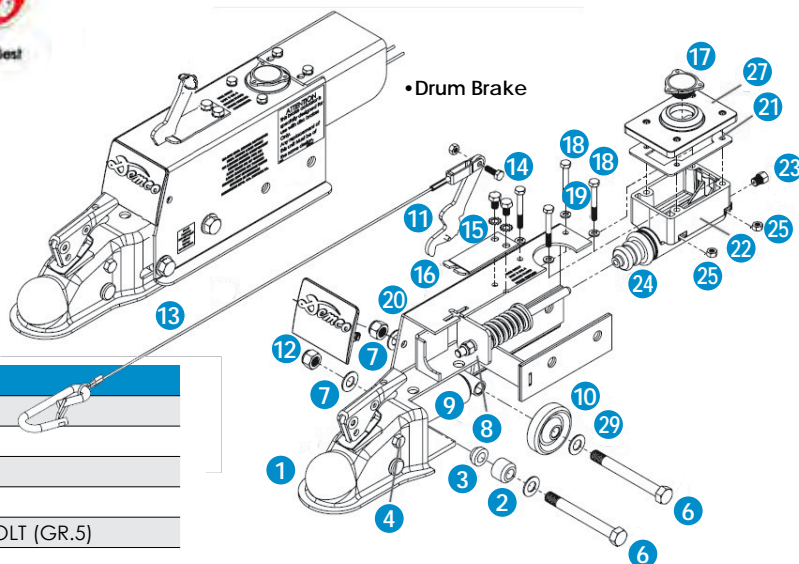
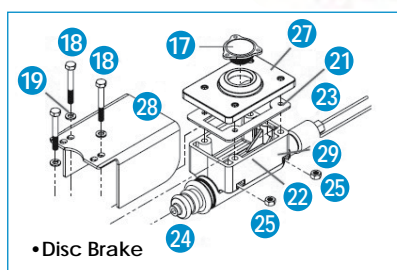

MODEL DA66B - PLATED LEVER LOCK ACTUATOR

REF NO	ITEM NO	QTY	DESCRIPTION
1	12190-95	1	6000# 2" LEVER LOCK COUPLER
2	SB23278	2	ROLLER
3	12151	2	FRONT ROLLER SPACER
4	02166	1	3/8"-16UNC X 2-3/4" HEX HEAD BOLT (GR.5)
5	07176	1	3/8"-16UNC STOVER LOCK NUT
6	05684	2	1/2"-13UNC X 4-7/16" HEX HEAD BOLT (GR.5)
7	02178	2	1/2"-13UNC NYLON INSERT LOCK NUT
8	12193	1	PUSH ROD ASSEMBLY
9	9050092	1	DAMPENER/ SHOCK
10	12103	2	REAR ROLLER SPACER
11	*9050080	1	EMERGENCY LEVER
12	12187	1	FRONT COVER COMPOSITE BLACK
13	*12200	1	28" CABLE
14	05960	2	5/16"-18UNC X 1/2" SELF-TAPPING SCREW
15	05424	2	5/16" EXTERNAL TOOTH LOCK WASHER
16	*9050081	1	EMERGENCY LEVER SPRING
17	7950007	1	MASTER CYLINDER CAP W/ DIAPHRAGM & O-RING
18	**00618	4	1/4"-20UNC X 2.00" HEX HEAD BOLT
19	**00057	4	1/4" SPRING LOCK WASHER
20	12191-95	1	OUTER CASE
21	**9050199	1	REPLACEMENT MASTER CYCLINDER GASKET
22	9050031	1	MASTER CYLINDER DRUM KIT (INCLUDES ** ITEMS)
	9050091	1	MASTER CYLINDER DISC KIT (INCLUDES ** ITEMS)
23	05679	1	0.125 FULL ORIFICE DRUM
	11993	1	INLINE BLOCKING SOLENOID DISC
24	**9050171	1	MASTER CYLINDER PROTROTIVE BOOT
25	**00062	4	1/4"-20 UNC NUT
26	9050198	1	THREADED CAP FOR MASTER CYLINDER
27	12267-95	1	SOLENOID COVER DISC
28	07283	1	10MM FLAT WASHER DISC
29	02384	4	1/2" X 14GA NR ZINC MACHINE WASHER

Master Cylinder Repair Kits



Coupler Repair Kit - 5696



ACTUATOR COUPLERS • 6,000 LB. CAPACITY

AD

•

ACTUATOR COUPLER PARTS BREAKDOWN



6K • 7K • 8K									
REF NO	DRUM	DISC	DESCRIPTION	QTY	REF NO	DRUM	DISC	DESCRIPTION	QTY
1	9050207	9050173	A-60 INNER MEMBER, ZINC (DISC /W SOLENOID)	1	23	9050228		A-84 BREAKAWAY CABLE CLIP	1
	9050177	9050213	A-60S ZINC BOLT-ON TOP MOUNT	1	24			A-84 PUSHROD RELEASE BRACKET	1
2	-	-	OUTER MEMBER	1	25			A-84 PUSHROD RELEASE BRACKET SP	1
3	9050223	-	MASTER CYLINDER ASSEMBLY (35154)	1	23	9050229		XR-84 BREAKAWAY CABLE CLIP	1
	-	9050191	MASTER CYLINDER FOR USE WITH SOLENOID (34762)	1	24			XR-84 PUSHROD RELEASE BRACKET	1
4	9050225		ROLLER PIN & PAD KIT	2	25			XR-84 PUSHROD RELEASE BRACKET SP	1
5			RETAINING RING	2*	26	9050230	HITCH PIN KIT (PIN, DECAL, RETAINING RING & CABLE)	1	
6			WEAR PAD, THIN (SIDES)	6	27	-	9050222	LOCKOUT SOLENOID 12V	1**
7			WEAR PAD, THICK (TOP/BOTT)	3	28	-	INCLUDED WITH ITEM 27	REVERSE VALVE DRAIN TUBE	1**
8			BREAKAWAY CABLE ASSEMBLY	1	29	-		NYLON CABLE TIE	2**
9			FRONT ROLLER (A-60 ONLY)	2	30	-		#10-32 MINI-BARB FITTING	1**
10			REAR ROLLER	2	31		9050235	SIDE LOCKOUT KIT	
11	9050224		SHOCK ABSORBER (32306)	1	32	-	-	NOT USED	
12	35112		PUSHROD ASSEMBLY	1***	33	9050208	9050209	A-75 INNER MEMBER, ZINC (DISC /W SOLENOID)	1
13	INCLUDED WITH ITEM 3		RESERVOIR PLATE COVER	1	33	9050214	9050206	A-75S ZINC BOLT-ON TOP MOUNT	
14	INCLUDED WITH ITEM 3		RESERVOIR DIAPHRAGM	1	34	INCLUDED WITH ITEM 4		A-75 TOP PAD (47710)	1
15	9050188		RESERVOIR PLUG	1	35		9050223	A-75 LATCH REPLACEMENT KIT (36368)	1
16	36360		A-60 LATCH REPLACEMENT KIT	1	36		9050231	A-75 HITCH PIN KIT (34566)	1
17	9050184		ROLLER PIN WASHER	2*	33	9050215	9050189	XR-84 INNER MEMBER, ZINC (DISC /W SOLENOID)	1
18	INCLUDED WITH ITEM 11		3/8-16 X 1.00" BOLT	1	33	9050216	9050217	XR-84S ZINC BOLT-ON TOP MOUNT	
19	INCLUDED WITH ITEM 11		SHOCK ABSORBER BUSHING	1	33	9050218	9050220	A-84 INNER MEMBER, ZINC (DISC /W SOLENOID)	1
20	INCLUDED WITH ITEM 4		CABLE ATTACHMENT PLATE	1	33	9050219	9050221	A-84S ZINC BOLT-ON TOP MOUNT	
21	32547		OUTER MEMBER CAP, PLASTIC	1	34	INCLUDED WITH ITEM 4		A-84 TOP PAD (47710)	2
22	INCLUDED WITH ITEM 4		A-60 TOP PAD (32592)	1	35		9050232	A-84 & A-160 HITCH PIN KIT (40110)	1
23	9050226		A-60 BREAKAWAY CABLE CLIP	1	36		9050234	A-84 & A-160 LATCH REPLACEMENT KIT (40120)	1
24			A-60 PUSHROD RELEASE BRACKET	1	* PER PIN ** NOT APPLICABLE TO ALL MODELS *** FOR SINGLE DISC OR TANDEM DRUM N/S-NOT SHOWN				
25			A-60 PUSHROD RELEASE BRACKET SP	1					
23	9050227		A-75 BREAKAWAY CABLE CLIP	1					
24			A-75 PUSHROD RELEASE BRACKET	1					
25			A-75 PUSHROD RELEASE BRACKET SP	1					

ACTUATOR COUPLER PARTS BREAKDOWN • 6K • 7K • 8K

ACTUATOR COUPLER PARTS BREAKDOWN

6K • 7K • 8K

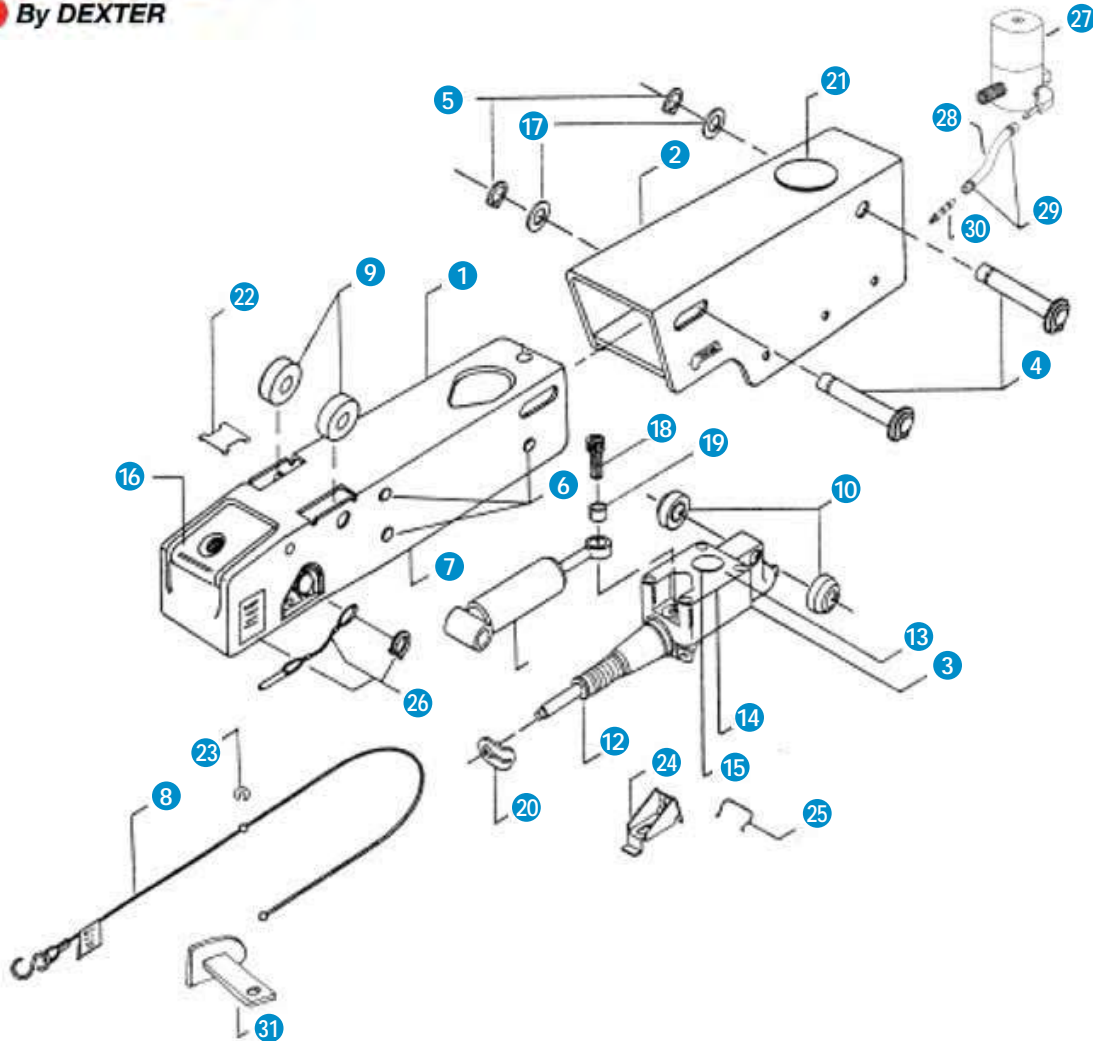
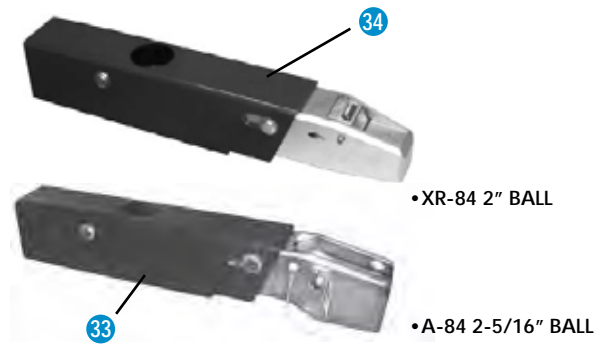

ACTUATOR COUPLER PARTS BREAKDOWN • 6K • 7K • 8K

ACTUATOR COUPLER PARTS BREAKDOWN

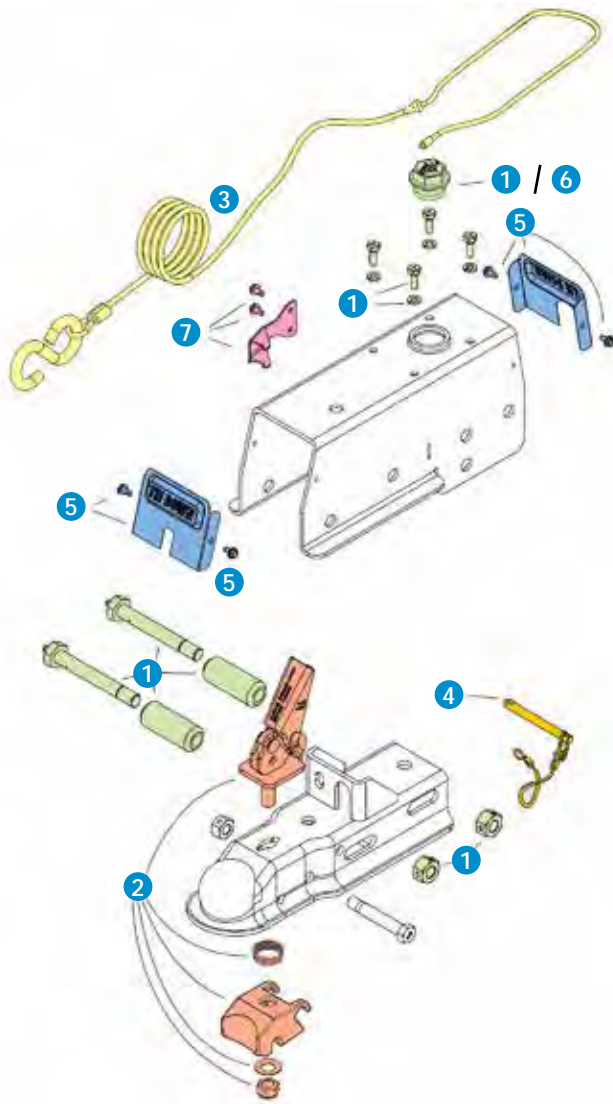

• Model 66
Master Cylinder

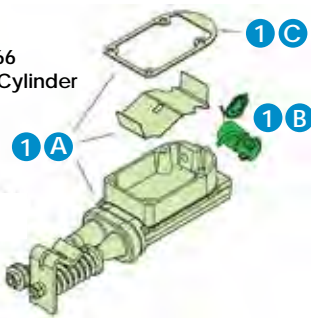

6K • MODEL 66		
REF NO	ITEM NO	DESCRIPTION
1A	47260K	DISC BRAKE MASTER CYLINDER KIT "LEVER LATCH" WITH GASKET AND FLUID BAFFLE, INCLUDES: MASTER CYLINDER AND CAP, 4 MOUNTING SCREWS WITH WASHERS, 2 ROLLERS WITH MATCHING NUTS AND BOLTS
1A	47268K	DRUM BRAKE MASTER CYLINDER KIT "LEVER LATCH" WITH GASKET AND FLUID BAFFLE, INCLUDES: MASTER CYLINDER AND CAP, 4 MOUNTING SCREWS WITH WASHERS, 2 ROLLERS WITH MATCHING NUTS AND BOLTS
1B	11253A	DISC BRAKE SOLENOID, BACK FLOW MODEL WITH RETURN HOSE
1C	48803	GASKET, FOR "LEVER LATCH" MASTER CYLINDERS
2	47261	LATCH KIT ASSEMBLY, (FOR SERIAL NUMBERS 16021 AND ABOVE)
2	47262	LATCH KIT ASSEMBLY, (FOR SERIAL NUMBERS 16020 AND BELOW)
3	50302	EMERGENCY STOP CABLE (E-STOP/BREAKAWAY) (FOR SERIAL NUMBERS 16020 AND BELOW)
3	50305	EMERGENCY STOP CABLE (E-STOP/BREAKAWAY), (FOR SERIAL NUMBERS 16021 AND ABOVE)
4	50301	SAFETY CABLE WITH STAINLESS STEEL PIN - INCLUDES MOUNTING SCREW
5	47264	ACTUATOR COVERS, INCLUDES FRONT AND REAR COVER PLATES AND 4 MOUNTING SCREWS
6	48804	MASTER CYLINDER FILL CAP WITH INTERNAL BLADDER
7	48845	SAFETY SPRING WITH TWO MOUNTING SCREWS (FOR SERIAL NUMBERS 16021 AND ABOVE)

ACTUATOR COUPLER PARTS BREAKDOWN • 6K • MODEL 66



ACTUATOR COUPLER PARTS BREAKDOWN



6K • MODEL 660E/660		
REF NO	ITEM NO	DESCRIPTION
1A	70461K	DISC BRAKE MASTER CYLINDER KIT "OPEN MODEL" WITH GASKET, INCLUDES: MASTER CYLINDER AND CAP, 4 MOUNTING SCREWS WITH WASHERS, 2 ROLLERS WITH MATCHING NUTS AND BOLTS
1A	70461KD	DISC BRAKE MASTER CYLINDER KIT "OPEN MODEL" WITH GASKET, INCLUDES: MASTER CYLINDER AND CAP, 4 MOUNTING SCREWS WITH WASHERS, 2 ROLLERS WITH MATCHING NUTS AND BOLTS
1	70519K	DISC BRAKE MASTER CYLINDER KIT "ENCLOSED MODEL" WITH GASKET, INCLUDES: MASTER CYLINDER AND CAP, 4 MOUNTING SCREWS WITH WASHERS, 2 ROLLERS WITH MATCHING NUTS AND BOLTS
1	70519KD	DISC BRAKE MASTER CYLINDER KIT "ENCLOSED MODEL" WITH GASKET, INCLUDES: MASTER CYLINDER AND CAP, 4 MOUNTING SCREWS WITH WASHERS, 2 ROLLERS WITH MATCHING NUTS AND BOLTS
1B	11286	DISC BRAKE SOLENOID - USED WITH DISC BRAKE ACTUATORS
1C	70470-3	GASKET - FOR "OPEN MODEL" MASTER CYLINDERS
2	70411	LATCH KIT ASSEMBLY, WITH DROP N GO COUPLER (SERIAL NUMBERS 17926 AND BELOW)
2	70412	LATCH KIT ASSEMBLY, WITH DROP N GO COUPLER (SERIAL NUMBERS 17927 AND ABOVE)
3	50317	EMERGENCY STOP CABLE (E-STOP / BREAKAWAY)
4	50301	SAFETY CABLE WITH STAINLESS STEEL PIN - INCLUDES MOUNTING SCREW
5	70462K	ACTUATOR COVERS, INCLUDES: FRONT AND REAR COVER PLATES AND 4 MOUNTING SCREWS
6	48986A	MASTER CYLINDER FILL CAP WITH INTERNAL BLADDER, 2.25" OPENING (E-MODELS)
6	70470-4	MASTER CYLINDER FILL CAP WITH INTERNAL BLADDER, 1.25" OPENING (OPEN MODELS)
7	48845	SAFETY SPRING WITH TWO MOUNTING SCREWS

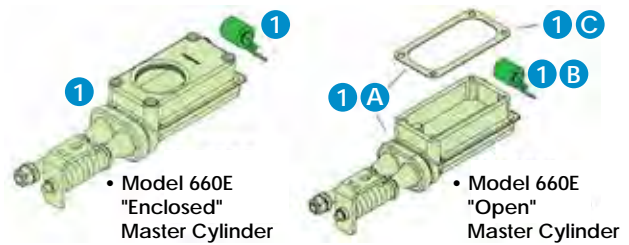
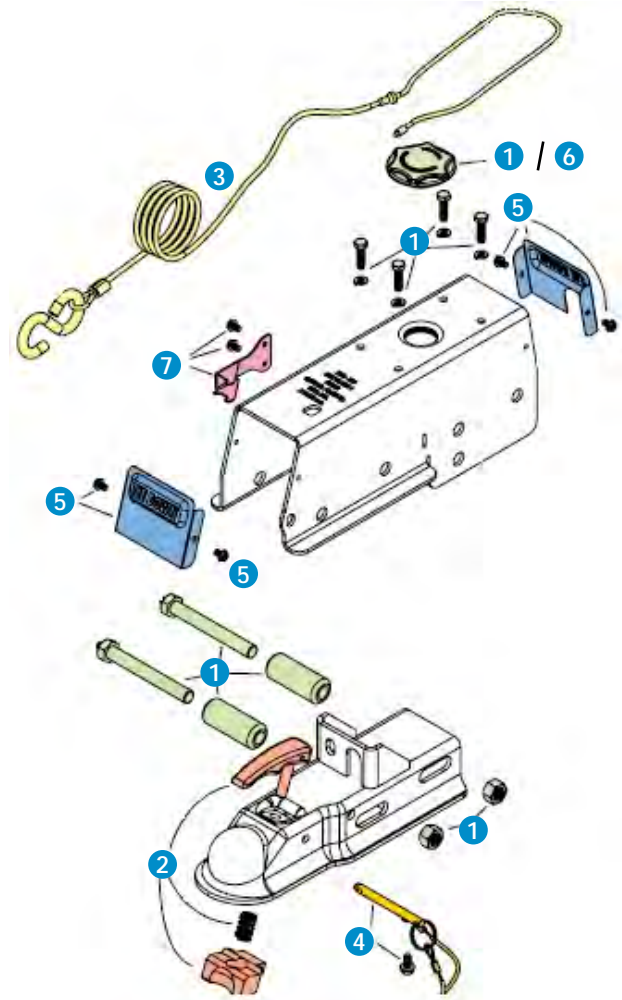

ACTUATOR COUPLER PARTS BREAKDOWN • 6K • MODEL 660E/660

ACTUATOR COUPLER PARTS BREAKDOWN

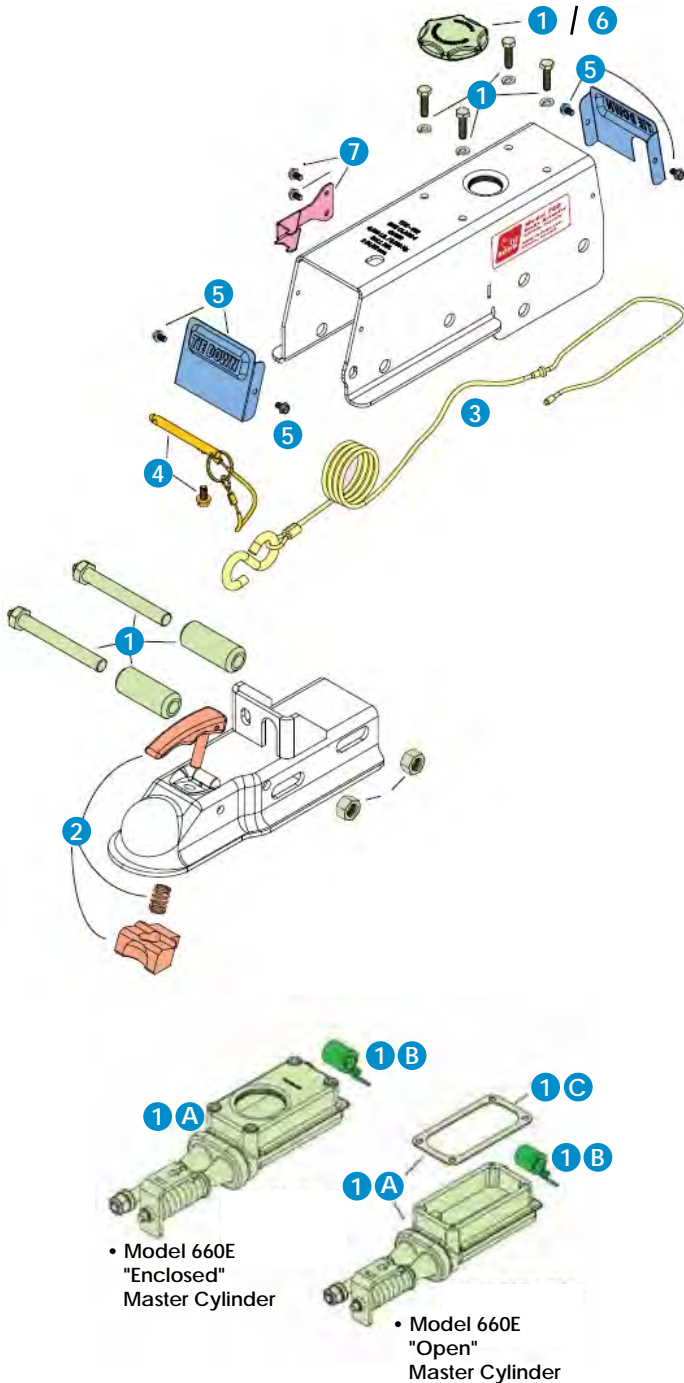

7K • MODEL 750E / 750 / 700		
REF NO	ITEM NO	DESCRIPTION
1A	47260K	DISC BRAKE MASTER CYLINDER KIT "LEVER LATCH" WITH GASKET AND FLUID BAFFLE, INCLUDES: MASTER CYLINDER AND CAP, 4 MOUNTING SCREWS WITH WASHERS, 2 ROLLERS WITH MATCHING NUTS AND BOLTS
1A	47268K	DRUM BRAKE MASTER CYLINDER KIT "LEVER LATCH" WITH GASKET AND FLUID BAFFLE, INCLUDES: MASTER CYLINDER AND CAP, 4 MOUNTING SCREWS WITH WASHERS, 2 ROLLERS WITH MATCHING NUTS AND BOLTS
1B	11253A	DISC BRAKE SOLENOID, BACK FLOW MODEL WITH RETURN HOSE
1C	48803	GASKET, FOR "LEVER LATCH" MASTER CYLINDERS
2	47261	LATCH KIT ASSEMBLY, (FOR SERIAL NUMBERS 16021 AND ABOVE)
2	47262	LATCH KIT ASSEMBLY, (FOR SERIAL NUMBERS 16020 AND BELOW)
3	50302	EMERGENCY STOP CABLE (E-STOP/BREAKAWAY), (FOR SERIAL NUMBERS 16020 AND BELOW)
3	50305	EMERGENCY STOP CABLE (E-STOP/BREAKAWAY), (FOR SERIAL NUMBERS 16021 AND ABOVE)
4	50301	SAFETY CABLE WITH STAINLESS STEEL PIN - INCLUDES MOUNTING SCREW
5	47264	ACTUATOR COVERS, INCLUDES FRONT AND REAR COVER PLATES AND 4 MOUNTING SCREWS
6	48804	MASTER CYLINDER FILL CAP WITH INTERNAL BLADDER
7	48845	SAFETY SPRING WITH TWO MOUNTING SCREWS (FOR SERIAL NUMBERS 16021 AND ABOVE)

ACTUATOR COUPLER PARTS BREAKDOWN • 7K • MODEL 750E / 750 / 700



ACTUATOR COUPLERS • 8,000 LB. CAPACITY •

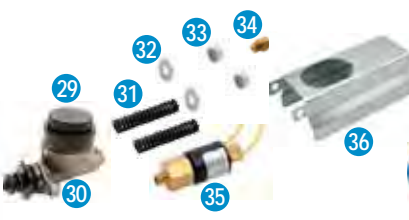
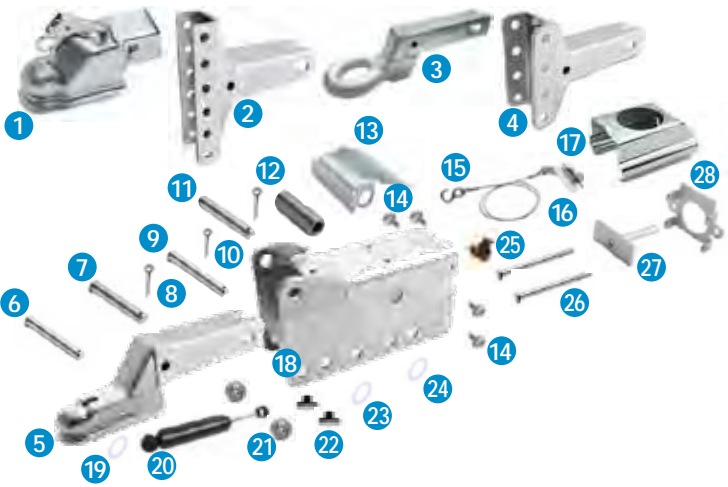

MODEL 6 PLATED ACTUATOR

REF NO	ITEM NO	DESCRIPTION	QTY
1	9050064	INNER SLIDE 2-5/16" BALL LATCH	1
2	4845600183	INNER SLIDE 6-HOLE CHANNEL	1
3	4045600	INNER SLIDE 3" LUNETTE EYE	1
4	4745100183	INNER SLIDE 4-HOLE CHANNEL	1
5	9050076	INNER SLIDE 2" BALL LATCH	1
6	2339000	BOLT, HEX 7/16" NF	1
7	9050138	DAMPER PIN	1
8	8750003	COTTER PIN 1/8" X 1-3/4"	2
9	1777300	MASTER PIN	1
10	0815200	COTTER PIN 3/16" X 1-1/4"	1
11	1776600	FRONT ROLLER PIN	1
12	1776300	FRONT ROLLER	1
13	4655900183	FRONT ROLLER COVER 8K RATING	1
14	1781500	5/16" X 1/2" GRADE 5 HEX BOLT	4
15	4594100	BREAKAWAY LEVER WITH PIN	1
16	1055500	S-HOOK (INCLUDED WITH 45941)	1
17	9050146	COVER	1
18	2480100183	OUTER CASE, PLATED 3" WIDE	1
	2493000	OUTER CASE, PLATED A-FRAME	1
19	2339100	LOCKNUT 7/16" THIN	1
20	9050019	SHOCK ABSORBER	1
21	9050246	REAR ROLLER	2
22	9050132	BEARING 0.075"	2
23	1831600	WASHER	1
24	1861900	FLAT WASHER	1
25	1780300	BREAKAWAY SPRING	1
26	1027300	HEX BOLT 5/16" X 5" GRADE 5	2
27	4390500	PUSH ROD ASSEMBLY	1
28	1776200	MASTER CYLINDER MOUNT PLATE	1
29	9050095	DIAPHRAGM TYPE FILLER CAP	1
30	9050096	MASTER CYLINDER DRUM BRAKE	1
	9050061	MASTER CYLINDER DISC BRAKE	1
31	9050140	SPRING	2
32	0782000	FLAT WASHER 3/8"	2
33	0797600	NUT 3/8"	2
34	9050116	ORIFICE 0.015" FOR DRUM BRAKES	1
	4750300	ORIFICE 0.125" FOR DISC BRAKES	1

37 - Master Cylinder Kit



38 - Coupler Repair Kit



Multi-Fit Parts



REF NO	ITEM NO	DESCRIPTION	QTY
35	6450624	SOLENOID VALVE	1
36	4836800183	SOLENOID VALVE COVER	1
37	1502600	MASTER CYLINDER REPAIR KIT 1" BORE	1
38	9050098	2-5/16" COUPLER REPAIR KIT	1
39	2496400	LOCKING RING	1
40	2420000	HAND WHEEL	1
41	2338300	HAND WHEEL LOCK	1
42	4336800	SPRING	1
43	4335800	2" BALL LATCH	1
44	1809000	LOCK PLATE	1
45	2338100	LATCH BOLT	1

Individual Components Are Special Order Parts Only.

ACTUATOR COUPLERS • 8,000 LB. CAPACITY

ACTUATOR COUPLERS • 8,000 LB. CAPACITY =

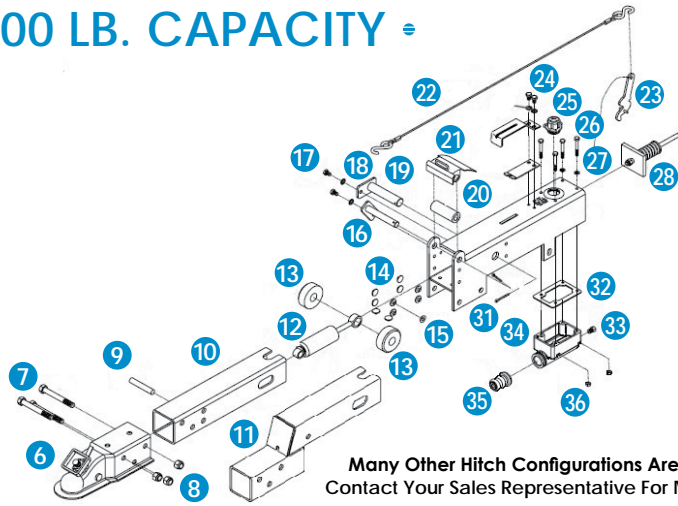
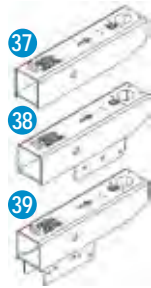
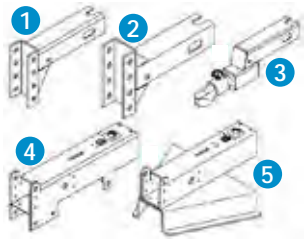

* Note: Actuator Capacity Is Degraded To The Lowest Component Capacity Rating.



Many Other Hitch Configurations Are Available. Contact Your Sales Representative For More Options.

MODEL DA91 8,000 LB GVWR • ACTUATOR

*8,000 Pound Capacity, Maximum Gvwr, 800 Pound Tongue Load. GVWR Limited To Ball Rating.

Note: -97 Primed Red -95 Zinc Plated

REF NO	ITEM NO	QTY	DESCRIPTION	REF NO	ITEM NO	QTY	DESCRIPTION
1	05937-97	1	CLEVIS CHANNEL DOWN (DROP)	22	6750146	1	3/32" CABLE WITH S-HOOKS ON BOTH ENDS
2	03734-97	1	CLEVIS CHANNEL CENTERED (STRAIGHT)	SB10555			REPLACEMENT S-HOOKS ONLY
3	05594-97	1	BULLDOG® 2-5/16" COUPLER WELDED TO DROP SLIDER TUBE	9050101	1		LEVER REPLACEMENT KIT (INCLUDES #22 & #30)
4	05975-97	1	STRAIGHT MOUNT OUTER CASING	23	9050080	1	EMERGENCY LEVER
5	05967-97	1	50° A-FRAME MOUNT OUTER CASING	24	9050082	2	5/16"-18UNC X 5/8 GRADE 5 HEX BOLT
6	05432	1	FULTON® 2" COUPLER	25	7950007	1	MASTER CYLINDER CAP W/DIAPHRAGM & O-RING
7	01896	3	1/2"-13UNC X 4" GRADE 5 HEX BOLT	05849	1		O-RING ONLY (NOT SHOWN)
8	02178	3	1/2"-13UNC NYLON INSERT LOCK NUT	26	00618	4	1/4"-20 UNC X 2" HEX BOLT
9	05441-95	1	FRONT SHOCK PIN 5/8" DIAM X 3" (DROP)	27	00057	4	1/4" LOCK WASHER
	05426-95	1	FRONT SHOCK PIN 5/8" DIAM X 3" (STRAIGHT)	28	05977	1	PUSH ROD ASSEMBLY
10	05440-97	1	STRAIGHT ACTUATOR SLIDER TUBE	29	03866-97	1	LEVER GUIDE
11	05421-97	1	DROP ACTUATOR SLIDER TUBE	30	05693-97	1	EMERGENCY LEVER SPRING
12	SB12426	1	SHOCK ABSORBER	31	02363	2	5/32" X 1-1/4" COTTER PIN
13	05403	2	BRAKE ACTUATOR ROLLER	32	9050142		CAST MASTER CYLINDER GASKET ONLY
14	05401	10	NYLATRON WEAR BUTTON	9050199			PLASTIC MASTER CYLINDER GASKET ONLY
15	09420	6	WASHER 3/4"OD X 21/64"ID STAINLESS STEEL	33	9050141	1	0.018 CONNECTOR ORIFICE
16	05423-97	1	TOP ROLLER PIN	34	05680	1	CAST MASTER CYLINDER WITH GASKET
17	04305	2	5/16"-18UNC X 1/2" GRADE 5 HEX BOLT	9050031	1		PLASTIC MASTER CYLINDER WITH GASKET
18	05424	4	5/16" EXTERNAL TOOTH LOCK WASHER	35	05687	1	MASTER CYLINDER PROTECTIVE BOOT
19	05422-97	1	INNER ROLLER PIN	36	00062	4	1/4"-20 UNC HEX NUT
20	05402	1	TOP ROLLER	37	11101-97	1	PRIMED RED NO MOUNT OUTER CASING
21	05419-97	1	TOP ROLLER COVER	38	11168-95	1	ZINC PLATED 3-HOLE MOUNT OUTER CASING
				39	11170-95	1	ZINC PLATED 5-HOLE MOUNT OUTER CASING

Other Hitch Configuration Options. Note: ?? = -97 Primed Red -95 Zinc Plated

11081-?? Slider With Flat Plate 	11075-?? Channel Center Slider 05557-?? 2" 7K Coupler 05823-?? 2/5-16" 8K Coupler 04051 5/8"-11 X 1-1/2 Bolt 03730 5/8" Stover Locknut 	15080-?? 2" Ez-Latch Flat Mount Coupler
11077-?? Channel Up Slider 05593-?? Clevis Hitch 04051 5/8"-11 X 1-1/2 Bolt 03730 5/8" Stover Locknut 	12113-?? 2" 6K Lever Lock Coupler 04051 5/8"-11 X 1-1/2 Bolt 03730 5/8" Stover Locknut 	12688-?? 2" Ez-Latch Coupler 04051 5/8"-11 X 1-1/2 Bolt 03730 5/8" Stover Locknut
11076-?? Channel Down Slider 09557-?? Pintle Ring 10-Ton 02434 5/8"-11 X 4-1/2" Bolt 02587 5/8" Nylon Locknut 	14976-?? 2" Ez-Latch Flat Mount Coupler 04051 5/8"-11 X 1-1/2 Bolt 03730 5/8" Stover Locknut 	12141-?? 2-5/16" Lever Lock Coupler Flat Mount
07678-?? 2-5/16" Ez-Latch Coupler 04051 5/8"-11 X 1-1/2 Bolt 03730 5/8" Stover Locknut 	11073-?? Straight Tube Slider 2-5/16" Coupler 	11074-?? Drop Tube Slider 2-5/16" Coupler

SAMPLE

PAGE LEFT BLANK SO THAT FOLLOWING PAGES
FORMED A SPREAD.

ACTUATOR COUPLERS PARTS BREAKDOWN =



12.5K MODEL 10 ACTUATOR							
REF NO	ITEM NO	DESCRIPTION	QTY	REF NO	ITEM NO	DESCRIPTION	QTY
1	*1601600	OUTER CASE, PAINTED, WELD-ON	1	N	0774500	GASKET FOR USE WITH EARLIER 1209900 ORIFICE	1
2	1020900	BEARING TOP & BOTTOM .125" THICK	6	23	0838900	CYLINDER BRACKET, LEFT HAND	1
3	1242700	BEARING (SIDE) .075" THICK	8	24	0827100	HEX BOLT, 3/8"-16 NC X 3" LONG	2
4	1601900	FRONT ROLLER	1	25	0797600	HEX NUT, 3/8" NC	2
5	0828800	FRONT ROLLER BOLT	1	26	1255200	STAR LOCKWASHER 3/8"	2
6	0799700	COTTER PIN 1/8" X 1"	2	27	0830100	PUSH ROD BLOCK	1
7	1601800	FRONT ROLLER COVER	1	28	1242600	DAMPER	2
8	0776800	BREAKAWAY CHAIN	1	29	0829100	REAR ROLLER	2
9	1055500	S-HOOK	2	30	1593500	MASTER PIN	2
10	1054100	BREAKAWAY LEVER ASSEMBLY	1	31	0815200	COTTER PIN 3/16" X 1-1/4"	2
11	1055200	WEATHER SEAL	1	32	1593400	DAMPER PIN	2
12	1052600	BREAKAWAY LOCK - LEFT HAND	1	40	0793700	LOCKWASHER 1/2" STANDARD	1
13	1052700	BREAKAWAY LOCK - RIGHT HAND	1	41	0798500	HEX NUT 1/2"-13 NC	1
14	0793800	LOCKWASHER 5/16" STANDARD	8	42	0144901	GREASE ZERK	1
15	0794900	HEX BOLT 5/16"-18 NC X 5/8" LONG	4	43	1861900	NYLON FLAT WASHER	2
16	1507000	CYLINDER COVER	1	N	2374600	DRUM BRAKE MASTER CYLINDER ASSY WITH BRACKETS	1
17	0794800	HEX BOLT 5/16"-18 NC X 1/2" LONG	4	N	4749501042	DISC BRAKE MASTER CYLINDER ASSY WITH BRACKETS	1
18	1608700317	INNER SLIDE, 4-HOLE LEVELER	1	51	1018700	1-1/4" MASTER CYLINDER REPAIR KIT FOR 2374400	1
19A	2374400	MASTER CYLINDER, 1-1/4" BORE, DRUM BRAKE	1	51A	4359100	MASTER CYLINDER BOOT	1
N	4831600	MASTER CYLINDER, 1-1/4" BORE, DRUM BRAKE	1	52	4748800	SOLENOID BACKUP VALVE, MALE 1/8" NPT AND 3/8" X 24 NF WITH INVERTED SEAT	1
19B	4747100	MASTER CYLINDER, 1-1/4" BORE, DRUM BRAKE	1	53	4836100183	BACKUP VALVE COVER, PLATED	1
20	0838800	CYLINDER BRACKET, RIGHT HAND	1	54	2478300183	INNER SLIDE DROP WITH 2-5/16" COUPLER, PLATED	1
21	4830601	FILLER CAP WITH DIAPHRAGM	1	55	1608400183	INNER SLIDE DROP WITH 2-5/16" COUPLER, PLATED	1
22	1209800	ORIFICE CONNECTOR, DRUM .015" 1/8" NPT	1	NOTE: N = NOT SHOWN IN DIAGRAM *SPECIAL ORDER			
N	1209900	ORIFICE, DRUM, EARLY TYPE 1/2" NF THREAD	1				

ACTUATOR COUPLERS PARTS BREAKDOWN • 12.5K MODEL 10

ACTUATOR PARTS BREAKDOWN =

MODEL 10 PLATED ACTUATOR DIAGRAM

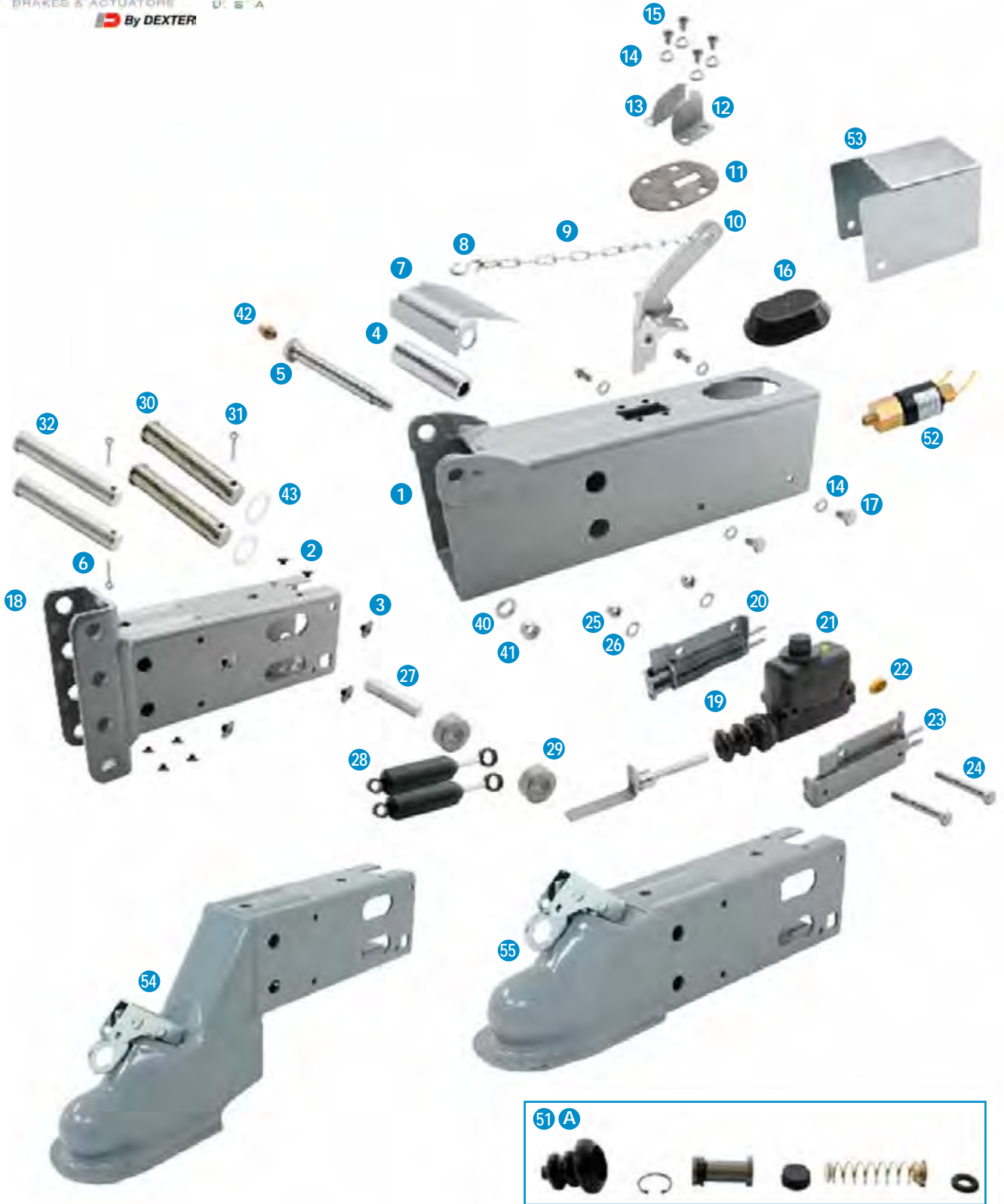

= ACTUATOR COUPLERS PARTS BREAKDOWN • 12.5K MODEL 10

ACTUATOR COUPLERS • 12,500 LB. CAPACITY •

Demco



Doing Our Best to Provide You the Best

*DA10 12,500 pound capacity, maximum GVWR, 1,200 pound tongue load. GVWR limited to ball rating.

*NOTE: Actuator capacity is degraded to the lowest component capacity rating.

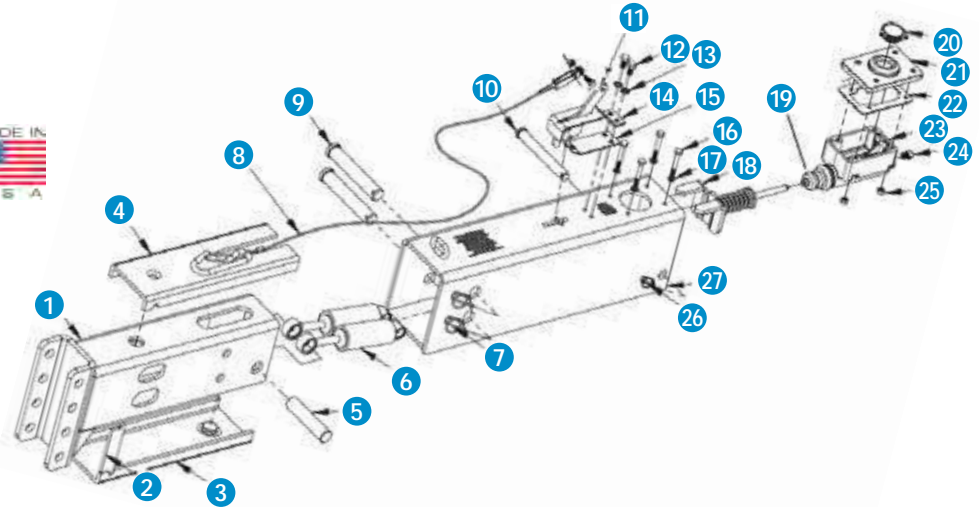

NOTE: ?? = -97 PRIMED RED -95 ZINC PLATED

DA10 12.5K ACTUATOR COMPONENT DIAGRAM

REF NO	ITEM NO	QTY	DESCRIPTION	REF NO	ITEM NO	QTY	DESCRIPTION	
1	11058-??	1	INNER SLIDE TUBE CHANNEL DOWN	15	05693-95	1	SAFETY LEVER SPRING	
	11053-??	1	INNER SLIDE TUBE CHANNEL CENTER	16	00618	4	BOLT 0.25NC X 2.00 HEX HEAD GRADE 5	
	11063-??	1	INNER SLIDE TUBE CHANNEL UP	17	00057	4	WASHER 0.25 SPRING LOCK	
2	***10964	2	DA10 SPACER	18	05989	1	PUSH ROD ASSEMBLY DA10	
	***10966	1	DA10 SLIDE CHANNEL BOTTOM		12891	1	PUSH ROD ASSEMBLY 1.25" BORE MASTER CYLINDER	
4	***10965	1	DA10 SLIDE CHANNEL TOP	19	05687	1	REPLACEMENT MASTER CYLINDER BOOT	
5	05973-95	1	FRONT SHOCK PIN	20	03876	1	MASTER CYLINDER CAP ASSEMBLY	
6	SB12426	2	SHOCK ABSORBER		05849			REPLACEMENT O-RING
		5482	1	MASTER CYLINDER REPAIR KIT (DISC)	21	12557	1	FILL PLATE FOR MASTER CYLINDER
		5398	1	MASTER CYLINDER REPAIR KIT (DRUM)	22	09153	1	CORK GASKET MASTER CYLINDER
7	12397	2	RUE RING LOCK COTTER 7/8 SHAFT	23	5650	1	DRUM BRAKES MASTER CYLINDER KIT	
8	05408	1	ACTUATOR SAFETY CABLE	5672	-		DISC BRAKES MASTER CYLINDER KIT	
				5783	-		1.25" BORE ALUMINUM MASTER CYLINDER KIT (DISC)	
10	05974-95	1	COLD HEADED CLEVIS PIN 0.625	24**	05679	1	BRAKE FITTING 0.125 FULL FLOW	
11	05951	1	EMERGENCY LEVER	25	00062	4	NUT 0.25NC HEX	
12	05961	2	BOLT 0.313NC X .625 HEX HEAD GRADE 5	26	12396	1	RUE RING LOCK COTTER 5/8 SHAFT	
13	05424	2	WASHER 0.313 EXTERNAL TOOTH LOCK	27	11068-??	1	DA10 OUTER CASE	
14	03866-95	1	EMERGENCY LEVER GUIDE					
			SB12099					
** Optional Substitutions:			SB12100					
			SB12098					

*** Optional Configurations

ACTUATOR COUPLERS • 12,500 LB. CAPACITY



ACTUATOR COUPLERS • 16,000 LB. CAPACITY •

MODEL A-160 ACTUATOR • 16K 2-5/16" COUPLER

16,000 lb. Capacity, Maximum GVWR, 1,600 Pound Tongue Load.
GVWR Limited To Ball Rating.

REF NO	ID NO	PARTS	QTY
1	19050S	IM, STRAIGHT, PLATED	1
1A	19050D	IM, DROP, PLATED	1
1B	19050B	I&M 2, BBOOLLT-SO N9/,1W6/-C12O UX P4L.5E"R +, I2N LNOECRK S NLUIDTES	1
2	19023	SLIDE BEARING	2
3	19041	LANYARD, HITCH PIN, SAFETY	1
4	19059	RIVET, SNAP, LANYARD	1
5	19034	OUTER CASE ASSEMBLY, BOLT-ON	1
6	19010	CAP, PLASTIC	1
7	19014	PIN, SHOCK ABSORBER, REAR	4
8	32262	RETAINER RING	8
9	32306	SHOCK ABSORBER	2
10	19003	PIN, SHOCK ABSORBER, FRONT	1
11	19066	LATCH HANDLE W/ DEAD BOLT	1
12	19067	LINK, BALL LOCK/LATCH	1
13	19068	SPRING, LINK, LATCH HANDLE	1
14	19069	BALL LOCK SUPPORT	1
15	19092	PIN, LATCH HANDLE	1
16	19091	COTTER PIN, LATCH PIN	2
17	19072	PIN, BALL LOCK SUPPORT	1
18	19005	BREAKAWAY CABLE ASSEMBLY	1
19	19006	B REAKAWAY LEVER	1
20	19011	LEVER GUIDE	1
20A	32522	DECAL, BREAKAWAY LEVER, RED/GREEN	1
21	19012	SAFETY STOP PLATE	1
22	19009	TOOTH WASHER	2
23	19008	BOLT, HEX 5/16 - 18, 1/2"	2
24	19073	TANDEM DISC PUSH ROD ASSY	1
24A	19074	TRIPLE DISC PUSH ROD ASSY	1
24B	19075	DRUM BRAKE PUSH ROD ASSY	1
25	34762	M/C-E-DISC ASSY	1
25A	32747	M/C-S, 1" DRUM ASSY	1
26	19018	SPACER, M/C,A160	2
27	34500	SOLENOID VALVE WITH FITTINGS	1
28	34508	REVERSE VALVE DRAIN TUBE	1
29	32269	NYLON CABLE TIE	2

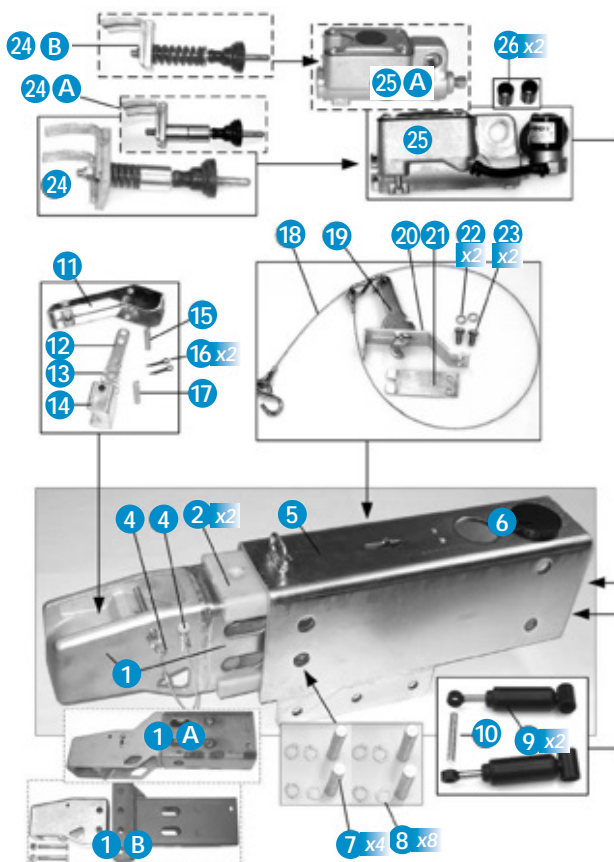

AVAILABLE CONFIGURATIONS:

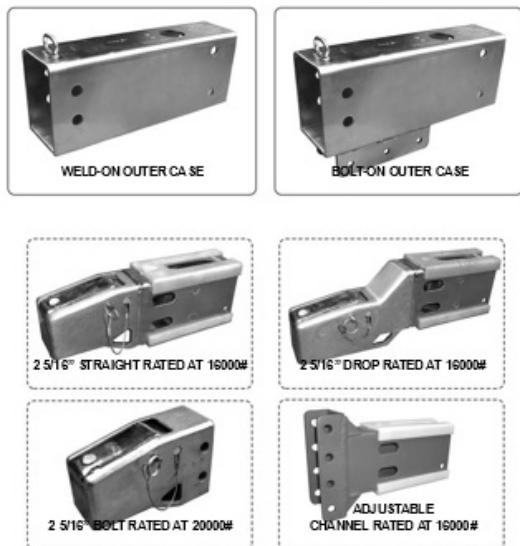

ACTUATOR COUPLERS • 16,000 LB. CAPACITY

ACTUATOR COUPLERS PARTS BREAKDOWN



20K • MODEL 20							
REF NO	ITEM NO	DESCRIPTION	QTY	REF NO	ITEM NO	DESCRIPTION	QTY
1	4488300	OUTER CASE WITH MOUNTING CHANNEL, PLATED	1	29	7010014	LEFT HAND CYLINDER SPRING BRACKET	1
2	4490400183	INNER SLIDE WITH 2-5/16" DROP COUPLER, PLATED	1	30	10541	BREAKAWAY LEVER ASSEMBLY	1
3	0828400	CENTERING RAIL	1	31	1055200	WEATHER SEAL	1
4	1601900	FRONT ROLLER, PLATED	2	32	9050126	RIGHT HAND BREAKAWAY LOCK	1
5	0828800	FRONT ROLLER BOLT, PLATED	2	33	9050125	LEFT HAND BREAKAWAY LOCK	1
6	0798500	HEX NUT, 1/2" NC	2	34	9050113	S-HOOK	2
7	0793700	LOCKWASHER, 1/2" STANDARD	2	35	9050127	SAFETY CHAIN	1
8	0144901	GREASE ZERK	4	36	1297600	INNER SLIDE, 3" LUNETTE EYE	1
9	0828900183	FRONT ROLLER COVER, PLATED	1	37	1058200183	INNER SLIDE, 4-HOLE LEVELER CHANNEL, PLATED	1
10	9050246	REAR ROLLER	6	38	8550013	3 BOLT CLEVIS HITCH	1
11	0829400	UPPER REAR ROLLER BOLT, 5" X 5/8" NF, GRADE 5	2	39	0909300	BOLT, 4-1/4" X 5/8" NC, GRADE 5	1
12	0797100	SLOTTED HEX NUT, 5/8" NF	3	40	10405	LOCKNUT, 5/8" NC	1
13	0332800	SPACER	1	41	0793800	LOCKWASHER, 5/16" STANDARD	6
	9050097	FILLER CAP REPLACEMENT FOR MASTER CYLINDER	1	42	9050116	ORIFICE CONNECTOR, DRUM BRAKE, 1/8" NPT	1
14	9050063	MASTER CYLINDER, DISC BRAKE, 1-1/4" BORE	1	*	9050115	ORIFICE, DRUM BRAKE, EARLIER 1/2" NF THREAD MASTER CYLINDER	1
15	0829700	SPACER SLEEVE	3	*	9050117	COPPER GASKET USED WITH 1209900 ORIFICE	1
16	0799400	COTTER PIN 1/8" X 1-1/4"	3	44	4488400	INNER SLIDE, 2-5/16" COUPLER, PLATED	1
17	9050065	DAMPER	2	45	4721500	ADJUSTABLE 2-5/16" COUPLER, PLATED	1
18	0829800	DAMPER PIN	2	46	8550099	LUNETTE EYE, 3" ADJUSTABLE, PLATED	1
19	9050245	PUSH ROD BLOCK	1	47	0829500	LOWER REAR ROLLER BOLT, 5/8" X 5" NF, GRADE 5	1
20	0799700	COTTER PIN 1/8" X 1"	2	48	4748800	SOLENOID VALVE FOR DISC BRAKES, MALE 1/8" NPT AND FEMALE 3/8" X 24 NF WITH INVERTED SEAT FOR FLARED FITTINGS	1
21	0794800	BOLT, 5/16" X 1/2" NC, GRADE 5	4				
22	1248900	STAR LOCKWASHER 5/16"	4	49	4836100183	COVER FOR SOLENOID VALVE, PLATED	1
23	9050122	MASTER CYLINDER COVER	1	50	1018700	2374400 MASTER CYLINDER REPAIR KIT	1
24	0827100	BOLT, 3" X 3/8" NC, GRADE 5	2	51	1058200183	INNER SLIDE, 4-HOLE LEVELER CHANNEL, PLATED	1
25	1255200	STAR LOCKWASHER 3/8"	2	*	1848700	2-5/16" COUPLER REPAIR KIT	1
26	0797600	HEX NUT, 3/8" NC	2	*	4749501042	DISC BRAKE MASTER CYLINDER ASSEMBLY WITH BRACKETS	1
27	0794900	BOLT, 5/16" X 5/8" NC, GRADE 5	6	NOTE: * = NOT SHOWN IN DIAGRAM			
28	7010013	RIGHT HAND CYLINDER SPRING BRACKET	1				

ACTUATOR COUPLERS PARTS BREAKDOWN • 20K • MODEL 20

ACTUATOR COUPLERS PARTS BREAKDOWN =



20K • MODEL 20 ACTUATOR DIAGRAM

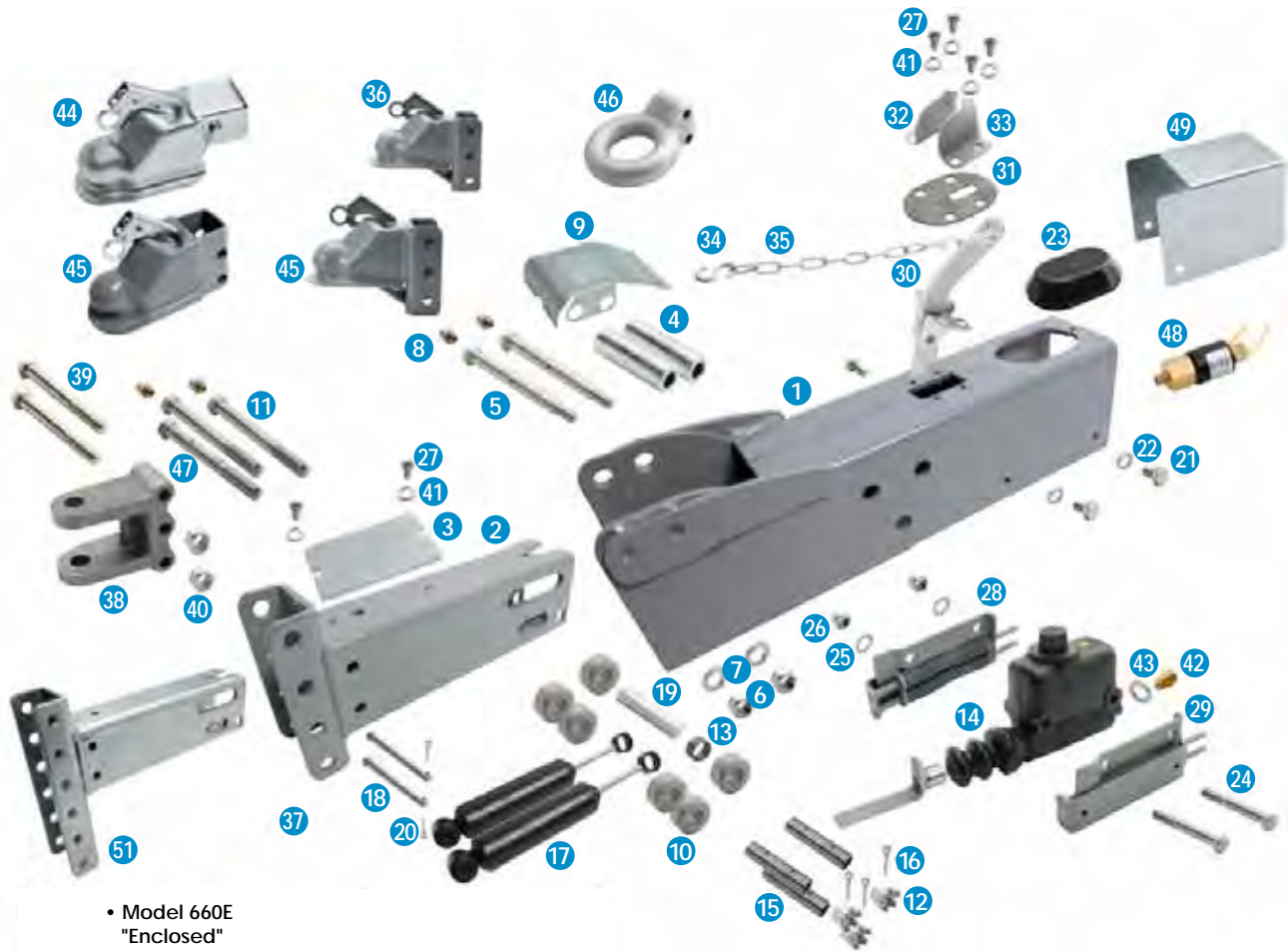

• Model 660E
"Enclosed"
Master Cylinder



• Master Cylinder Repair Kit

= ACTUATOR COUPLERS PARTS BREAKDOWN • 20K • MODEL 20

ACTUATOR COUPLERS • 20,000 LB. CAPACITY •



*DA20 20,000 pound capacity, maximum GVWR, 2,000 pound tongue load. GVWR limited to ball rating.

*NOTE: Actuator capacity is degraded to the lowest component capacity rating.

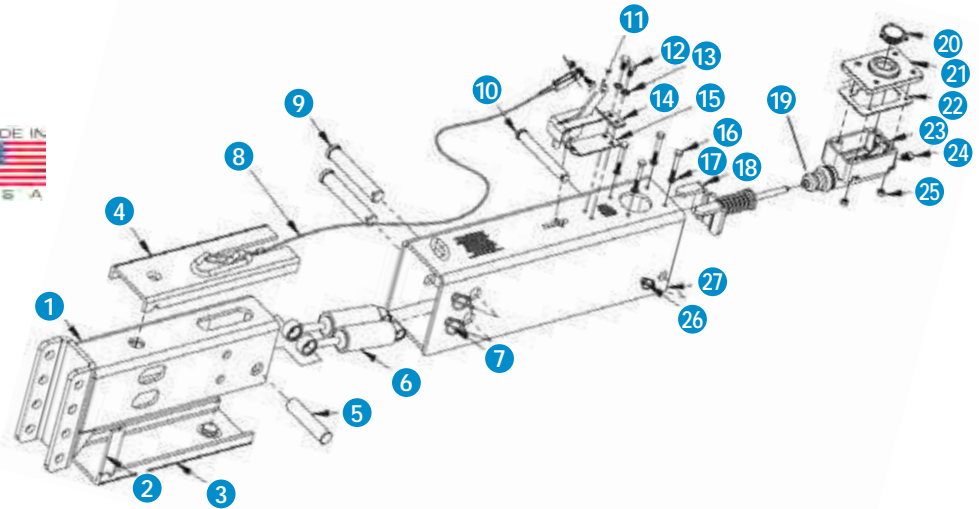

NOTE: ?? = -97 PRIMED RED -95 ZINC PLATED

DA20 20K ACTUATOR COMPONENT DIAGRAM

REF NO	ITEM NO	QTY	DESCRIPTION	REF NO	ITEM NO	QTY	DESCRIPTION
1	11042-??	1	INNER SLIDE TUBE CHANNEL DOWN	15	05693-95	1	SAFETY LEVER SPRING
	11040-??	1	INNER SLIDE TUBE CHANNEL CENTER	16	00618	4	BOLT 0.25NC X 2.00 HEX HEAD GRADE 5
	11050-??	1	INNER SLIDE TUBE CHANNEL UP	17	00057	4	WASHER 0.25 SPRING LOCK
2	***10964	2	DA20 SPACER	18	03534	1	PUSH ROD ASSEMBLY DA20
	***10963	1	DA20 SLIDE CHANNEL BOTTOM		11724	1	PUSH ROD ASSEMBLY 1.25" BORE MASTER CYLINDER
3	***10962	1	DA20 SLIDE CHANNEL TOP	19	05687	1	REPLACEMENT MASTER CYLINDER BOOT
4	03409-95	1	FRONT SHOCK PIN	20	03876	1	MASTER CYLINDER CAP ASSEMBLY
6	SB12426	2	SHOCK ABSORBER		05849		REPLACEMENT O-RING
	5482	1	MASTER CYLINDER REPAIR KIT (DISC)	21	12557	1	FILL PLATE FOR MASTER CYLINDER
	5398	1	MASTER CYLINDER REPAIR KIT (DRUM)	22	09153	1	CORK GASKET MASTER CYLINDER
7	12397	2	RUE RING LOCK COTTER 7/8 SHAFT	23	5650	1	DRUM BRAKES MASTER CYLINDER KIT
8	05408	1	ACTUATOR SAFETY CABLE		5672	-	DISC BRAKES MASTER CYLINDER KIT
9	03411-95	2	COLD HEADED CLEVIS PIN 0.875		5783	-	1.25" BORE ALUMINUM MASTER CYLINDER KIT (DISC)
10	03411-95	1	COLD HEADED CLEVIS PIN 0.625	24**	05679	1	BRAKE FITTING 0.125 FULL FLOW
11	05951	1	EMERGENCY LEVER	25	00062	4	NUT 0.25NC HEX
12	05961	2	BOLT 0.313NC X .625 HEX HEAD GRADE 5	26	12396	1	RUE RING LOCK COTTER 5/8 SHAFT
13	05424	2	WASHER 0.313 EXTERNAL TOOTH LOCK	27	03412-??	1	DA20 OUTER CASE
14	03866-95	1	EMERGENCY LEVER GUIDE				
** Optional Substitutions:	SB12099	0.031	ORIFICE BRAKE FITTING				
	SB12100	0.024	ORIFICE BRAKE FITTING				
	SB12098	0.016	ORIFICE BRAKE FITTING				

*** Optional Configurations

ACTUATOR COUPLERS • 20,000 LB. CAPACITY

ELECTRIC OVER HYDRAULIC =



BRAKERITE II SEVERE DUTY ACTUATOR KIT

ITEM NO	DESCRIPTION
7010010	BRAKERITE II SD DISC/DRUM 1.5K PSI
7010012	FORD/CHEVY ADAPTER*
7010011	DRUM BRAKE REDUCER**

*NEEDED FOR FORD & CHEVY VEHICLES WITH INTEGRAL TOW PACKAGE ON 2006.5 & UP MODELS.

**NEEDED FOR DRUM BRAKES.

ACTUATOR KIT PARTS LIST INCLUDED IN 7010010

ITEM NO	DESCRIPTION
9050143	BRAKERITE II
9050102	SD CONTROL MODULE
6500086	SD WIRING HARNESS
6500084	BRAKERITE II BREAKAWAY HARNESS
9050148	BRAKE II BREAKAWAY HARNESS BATTERY SWITCH

BRAKERITE EHB ELECTRO HYDRAULIC BRAKE ACTUATORS

ITEM NO	DESCRIPTION
7010015	BRAKERITE EHB DISC 1.5K PSI
9050130	BRAKERITE EHB DRUM 1K PSI
7010021	FORD/CHEVY ADAPTER*

*NEEDED FOR FORD & CHEVY VEHICLES WITH INTEGRAL TOW PACKAGE ON 2006.5 & UP MODELS.

Brakerite EHB is designed to be hard wired into your trailer's electrical system. All components are self-contained under the BrakeRite cover.



BrakeRite II Severe Duty provides complete plug-in wiring harnesses for a plug and play installation.



•7010015

ELECTRIC OVER HYDRAULIC

Titan has been a pioneer in the Electro Hydraulic Brake (EHB) actuator industry beginning in the early 1990s. In the new millennium, Titan developed and tested the BrakeRite EHB that was introduced in early 2002.

The features of the BrakeRite EHB and the BrakeRite II include:

- First in the field with an electronic proportional pressure valve
- The most rapid response from brake actuation to total dynamic braking in the industry
- Hybrid electronic control board compatible with most in-cab brake controllers
- Ongoing plant performance testing and each production unit is bench tested
- Research and development is standard at Titan
- Pump/motor based
- Isolated fluid reservoir with diaphragm type valve filler cap

ELECTRIC OVER HYDRAULIC

HYDRASTAR

CONVERSION SYSTEM
Works with FORD, DODGE and GM Factory Brake Controllers.

- 1-3 Brakes
- Brake Actuator for DISC or DRUM Brakes!
- Complies with CFR-393 Federal Braking Requirement.
- Meets All D.O.T. Regulations.
- 2-Year Limited Warranty



MODEL ID NO	ITEM NO	ID NO
1000 PSI (HBA-10)	7010001	381-7065
1200 PSI (HBA-12)	7010009	381-7066
1600 PSI (HBA-16)	7010002	381-7067
1000 PSI (MHBA-10) PLUG & PLAY KIT	7010019	481-8065
1600 PSI (MHBA-16) PLUG & PLAY KIT	7010018	481-8067

HYDRASTAR PLUG AND PLAY KIT INCLUDES:
Hydrastar Electric over Hydraulic Actuator, 7 way insulated trailer harness, 7 pole junction box, Adhesive backed mounting pads, 6' split wire loom, all mounting/wiring hardware and connectors.



Note: 9500067 Is Required If Line Kit 9500014 Or 9500015 Is Selected.

The Hydrastar Electric Over Hydraulic (Eoh) Trailer Brake Actuator Gives You The Reliability And Confidence You Expect And Need From Your Trailer Braking System. With Hydrastar You Get The Fastest Response Time For Shorter Stopping Distance, So In Emergency Situations And In Your Day To Day Towing, You Can Control Those Precious Fractions Of A Second That Matter When It Comes To Stopping Your Trailer.

Industry Leading Hydrastar Actuators Are Easy To Install And Meet All Dot And Federal Braking Requirements - Unlike Surge Brakes, Which Are Illegal In Many States. Hydrastar Has Improved The Stopping Performance For Trailers Hauling Boats, Rv/Towables, Horses, Cars, Construction And Farm Equipment, And Many Other Loads.

Features & Benefits:

- 2 Year Warranty From Date Of Purchase
- Sealed, Extruded, Anodized Aluminum Housing (Not Cast Or Plastic)
- Dimensions: 11.8" L X 3" W X 7.3" H
- Trailer Mounted
- 12 V DC Operation
- Solid State Electronics
- Uses Dot 3 Or Dot 4 Brake Fluid
- Easy To Install, (4) 12Ga Wires
- Black - Constant Power
- Blue - Brake Controller
- White - Ground
- Yellow - Break-Away
- Available In 1000,1200, And 1600 Psi For Any Trailer Configuration With 1-3 Axles
- Meets All Dot Regulations
- Complies With Cfr-393 Braking Requirements



ACCESSORIES

REF NO	ITEM NO	DESCRIPTION
1	7010003	HBA-CAM: ALLOWS GEN 6 OR LATER HYDRASTAR ACTUATORS TO WORK WITH INTEGRAL ELECTRIC BRAKE CONTROLLERS ON FORD MODEL YEARS 2007-2008 AND CHEVROLET MODEL YEARS 2007-CURRENT. SPLICES INTO HYDRASTAR ACTUATOR WIRING AND CAN BE MOUNTED ANYWHERE.
2	7010006	HYDRASTAR REPLACEMENT CAP

ELECTRIC OVER HYDRAULIC



ELECTRIC OVER HYDRAULIC



Braking Performance You Can Depend On Stop After Stop.

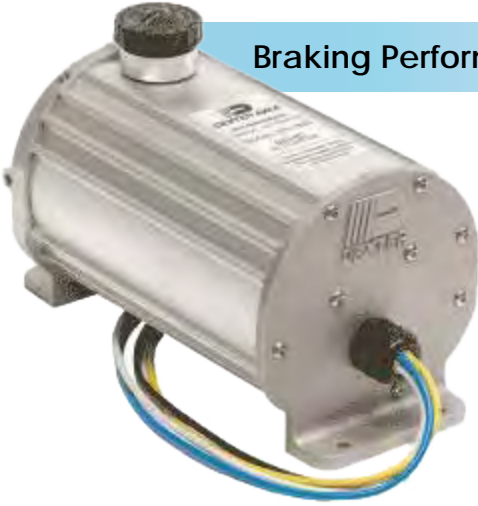

Dexter Axle Brake Actuator Provides 1,000 Psi (For Drum Brakes) And 1,600 Psi (For Disc Brakes) Of Pressure For 1-3 Axles.



AXLE TYPE APPLICATION	MODEL ID NO	ITEM NO	ID NO
DRUM	1000 PSI (DX-1000)	7010004	K71-650-00
DISC	1600 PSI (DX-1600)	7010005	K71-651-00

The Dexter Actuators ARE NOT Compatible With The GM Integrated Brake Controller.

ACCESSORIES

ITEM NO	DESCRIPTION
7010006	BRAKE ACTUATOR REPLACEMENT CAP

WORKS WITH FORD AND DODGE FACTORY BRAKE CONTROLLERS

7010004 Dexter K71-650-00 Electro/Hydraulic Brake Actuator Provides 1000 Psi Of Pressure For 1-3 Axles Equipped With Drum Brakes. Brake Fluid Pressure Is Proportional To The Electronic Brake Controller Signal. Sealed Housing Provides A Weather Tight Seal. Five Year Limited Warranty.

7010005 Dexter K71-651-00 Electro/Hydraulic Brake Actuator Provides 1600 Psi Of Pressure For 1-3 Axles Equipped With Disc Brakes. Brake Fluid Pressure Is Proportional To The Electronic Brake Controller Signal. Sealed Housing Provides A Weather Tight Seal. Five Year Limited Warranty.

Meets Or Exceeds All D.o.t. Regulations And Federal Braking Requirements.

All Stainless Steel Fasteners For Superior Corrosion Resistance.

Goretite® Seals Protect The Circuit Board From Water And Provide Protection Against The Elements.

Finned Housing Design Helps Dissipate Heat More Efficiently For Long-Lasting Durability.

Incorporates Enhanced Wiring Protection To Prevent Possible Damage To The Unit If Wired Improperly.

Solid State Electronics For Improved Performance And Compatibility With Most Aftermarket And Oem Integrated Electric Brake Controllers On The Market.

Large Brake Fluid Reservoir And Self-Priming Pump Reduce The Time Required For Brake Bleeding While Preventing The System From Running Dry During The Process.

Unrestricted By Brake Fluid Displacement Requirements Eliminating The Risk Of Starving Brakes For Fluid.

Allows For Use On Single, Tandem, Or Tripler Axle Configurations Regardless Of Capacity.

Provides Braking Power When Moving The Trailer In Reverse.

Eliminates The Feeling Of Being Pushed By The Trailer Which Reduces The Possibility Of Jackknife Situations.

Eliminates Brake Drag Commonly Experienced When Using Surge Actuator Systems In Downhill Towing.



ITEM NO	ID NO	DESCRIPTION
6550028	034-285-00	9-AMP/HOUR BREAKAWAY BATTERY AND CHARGER KIT

*Note: Requires 6550028. Separate Purchase.

9500067



9500067 Is Required If Hydraulic Line Kit 9500014 Or 9500015 Is Selected.

ITEM NO	ID NO	DESCRIPTION
6500012	058-008-00	INERTIA-ACTIVATED ELECTRIC BRAKE CONTROLLER.



ELECTRIC OVER HYDRAULIC

HYDRAULIC BRAKE LINES

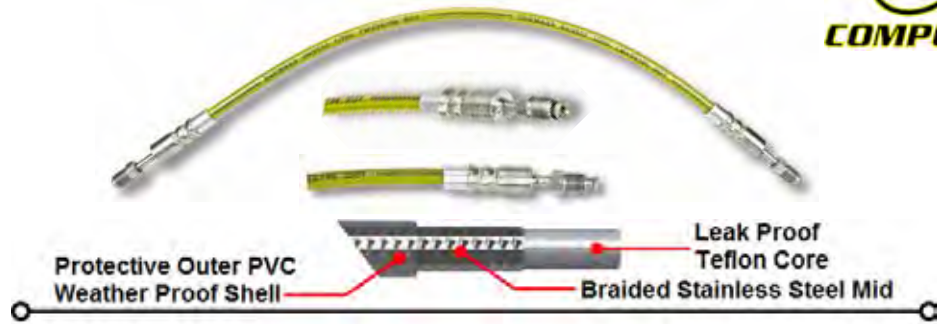

STAINLESS STEEL BRAIDED				
Low and High Temperature Ranges -70°C (-94°F) to +260°C (+500°F) • Bursting Strength 15, 110psi				
ITEM NO	ID NO	LENGTH	END	DESCRIPTION
9500084	DOT-SSFL-18"	18"	3/16"	DOT APPROVED STAINLESS STEEL BRAIDED FLEX LINE WITH TEFLON CORE. SS INVERTED FLARE MALE ON BOTH ENDS.
9500085	DOT-SSFL-24"	24"	3/16"	
9500086	DOT-SSFL-30"	30"	3/16"	
9500087	DOT-SSFL-36"	36"	3/16"	



RUBBER FLEX HOSE				
Low and High Temperature Ranges -50°C (-58°F) to +121°C (+250°F) • Bursting Strength 10, 950psi				
ITEM NO	ID NO	LENGTH	END	DESCRIPTION
9500089	DOT-RFL-12"	12"	3/16"	DOT APPROVED RUBBER FLEX LINE BRASS INVERTED FLARE MALE ON BOTH ENDS.
9500090	DOT-RFL-16"	16"	3/16"	
9500091	DOT-RFL-18"	18"	3/16"	
9500092	DOT-RFL-24"	24"	3/16"	
9500093	DOT-RFL-36"	36"	3/16"	
9500094	DOT-RFL-38"	38"	3/16"	
9500095	DOT-RFL-60"	60"	3/16"	
9500096	DOT-RFL-72"	72"	3/16"	
9500097	DOT-RFL-78"	78"	3/16"	
9500098	DOT-RFL-220"	220"	3/16"	
9500099	DOT-RFL-240"	240"	3/16"	
9500100	DOT-RFL-260"	260"	3/16"	
9500101	DOT-RFL-280"	280"	3/16"	
9500102	DOT-RFL-312"	312"	3/16"	

HYDRAULIC BRAKE LINES

HYDRAULIC BRAKE LINE KITS • DRUM

Hydraulic Line Kits Come Complete With All Fittings Needed To Connect Hydraulic Brake Axles. Kits Begin With A Basic Single Line Kit And With The Additional "Add-On" Kit You Can Plumb More Brakes. Choose From Steel (With Alum Galvan Finish), Stainless Steel, Torsion Or Dot Approved "Flex" Line Kits. The Standard

Hydraulic Brake Line Kits Listed Below Are Designed To Be Used On Trailers Using Either Surge Brake Actuators Or Power Brake Actuators And Are Manufactured Using Double Wall Brazed Low Carbon Steel Tubing In Accordance With Sae J527.



ITEM NO	ID NO	DESCRIPTION
9500038	AG-100SA	LINE KIT - SINGLE AXLE DRUM 3/16" X 15'
9500040	S-100SA	LINE KIT - SINGLE AXLE DRUM STAINLESS STL 3/16" X 15'

Choose This Line Kit For A Single Axle Drum Trailer. For A Tandem, Add-On One Of The Kits Below. I.e., If You Select Ag-100Sa, Then For A Tandem Select Ag-130Sa Also.

DRUM		
REF NO	QTY	DESCRIPTION
1	1	3/16" X 15' BRAKE LINE
2	1	3/16" X 72" BRAKE LINE
3	1	3/16" X 17.5" BRAKE LINE
4	1	18" FLEX BRAKE LINE ML/FML
5	1	HOSE BRACKET
6	3	HOSE CLIP
7	3	3/16" IF UNION TEE W/ BRKT
8	3	TUBE CLAMP
9	3	SELF TAB SCREW
10	3	AXLE STRAP
11	1	1/8 MPT X 3/16 IF ADAPTER

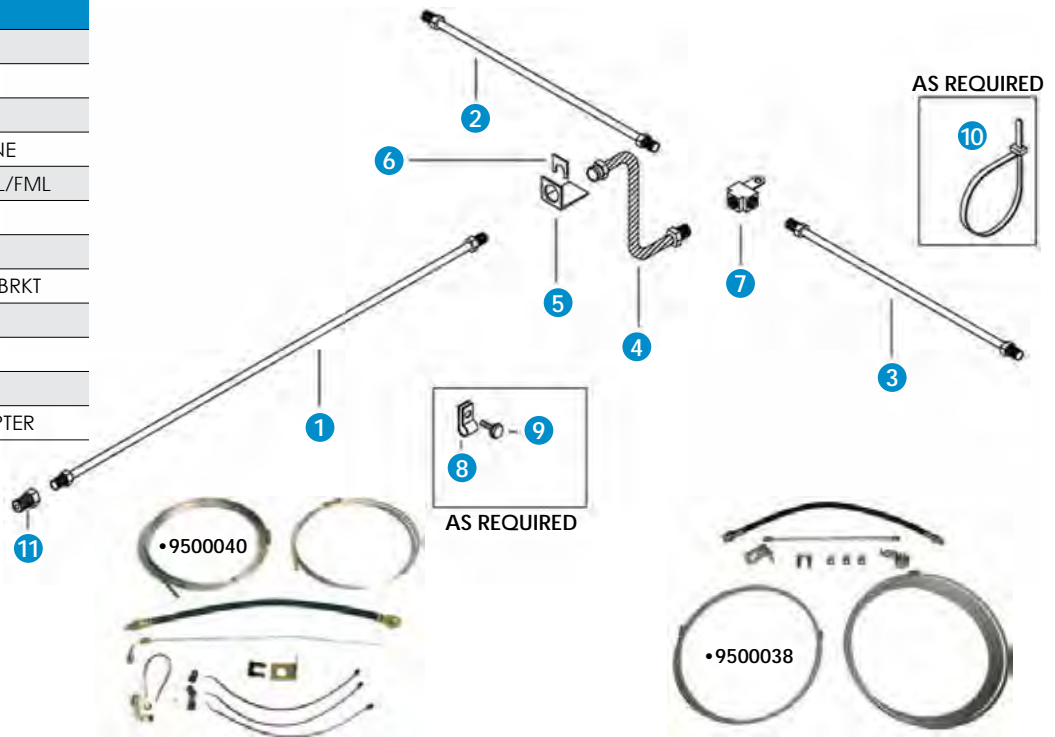

ADD-ON KITS		
ITEM NO	ID NO	DESCRIPTION
9500039*	AG-130SA	LINE KIT - ADD FOR AG-100SA (ABOVE)
9500041*	S-130SA	LINE KIT - ADD FOR S-100SA (ABOVE)

* Add One Of These Kits For Each Additional Axle. I.e., A Triple Would Require One Kit From Above Plus Two Of The Matching Add-On Kits.

DRUM		
REF NO	QTY	DESCRIPTION
1	1	3/16" X 30" BRAKE LINE
2	1	3/16" X 72" BRAKE LINE
3	1	3/16" X 17.5" BRAKE LINE
4	1	18" FLEX BRAKE LINE ML/FML
5	1	HOSE BRACKET
6	1	HOSE CLIP
7	1	3/16" IF UNION TEE W/ BRKT
8	1	TUBE CLAMP
9	1	SELF TAB SCREW
10	3	AXLE STRAP
11	1	3/16" IF ADAPTER TEE

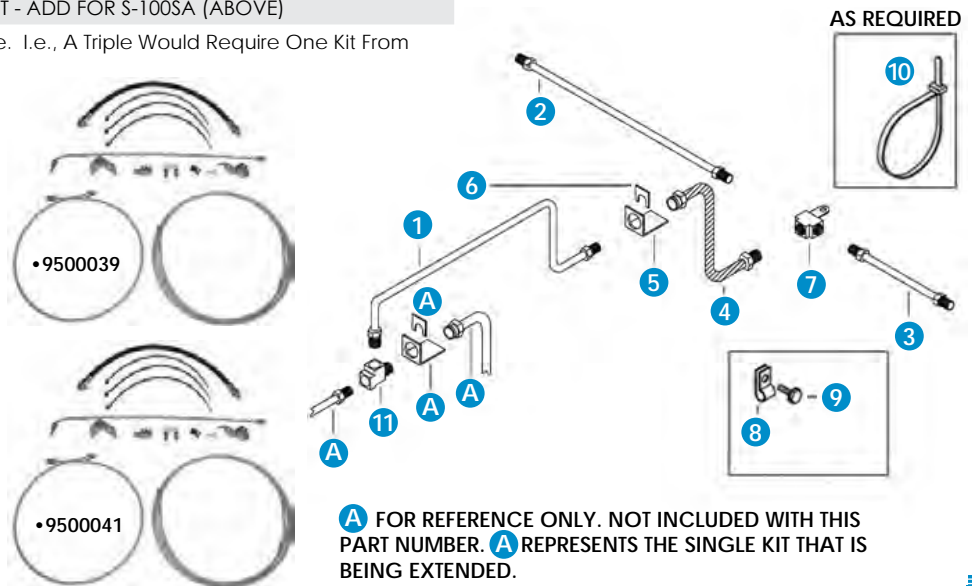

A FOR REFERENCE ONLY. NOT INCLUDED WITH THIS PART NUMBER. **A** REPRESENTS THE SINGLE KIT THAT IS BEING EXTENDED.

HYDRAULIC BRAKE LINE KITS • DISC •

Hydraulic Line Kits Come Complete With All Fittings Needed To Connect Hydraulic Brake Axles. Kits Begin With A Basic Single Line Kit And With The Additional "Add-On" Kit You Can Plumb More Brakes. Choose From Steel (With Alum Galvan Finish), Stainless Steel, Torsion Or Dot Approved "Flex" Line Kits. The Standard

Hydraulic Brake Line Kits Listed Below Are Designed To Be Used On Trailers Using Either Surge Brake Actuators Or Power Brake Actuators And Are Manufactured Using Double Wall Brazed Low Carbon Steel Tubing In Accordance With Sae J527.

ITEM NO	ID NO	DESCRIPTION
9500044	AG-701-TR	LINE KIT - SINGLE AXLE TORFLEX OR DISC DELUXE 3/16" X 15'

Choose This Line Kit For A Single Axle Torflex Or Disc Trailer. For A Tandem, Add-On One Of The Kits Below. I.e., If You Select Ag-701-Tr, Then For A Tandem Select Ag-700-Ak Also.

DISC		
REF NO	QTY	DESCRIPTION
1	1	3/16" X 15' BRAKE LINE
2	1	3/16" X 72" BRAKE LINE
3	2	3/16" X 5" BRAKE LINE WITH 13" FLEX BRAKE LINE ML/FML WITH SWIVEL ENDS ON HOSE
4	1	3/16" IF STREET TEE
5	2	HOSE BRKT
6	2	HOSE CLIP
7	1	1/8 MPT X 3/16 IF ADAPTER
8	4	TUBE CLAMP
9	4	SELF TAB SCREW

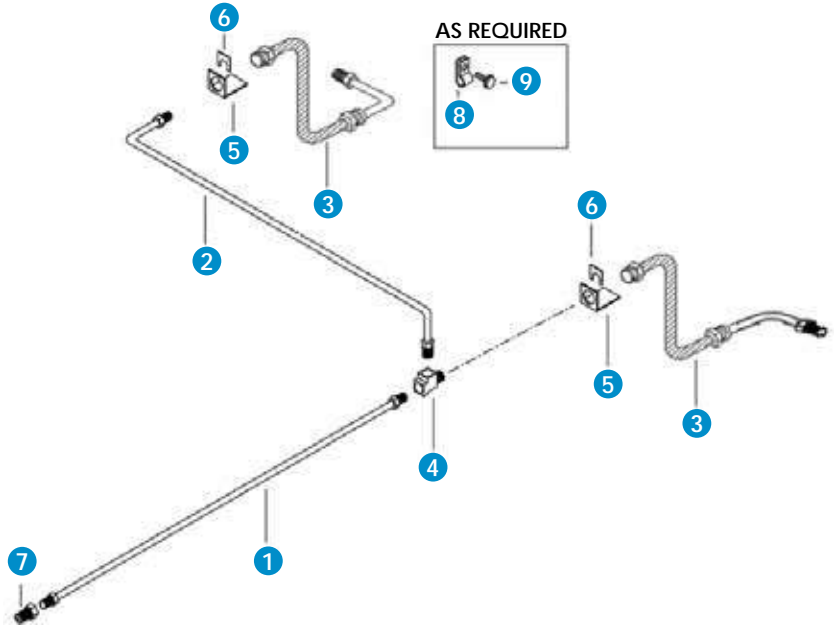

ADD-ON KITS		
ITEM NO	ID NO	DESCRIPTION
9500076	192-7089	HYDRAULIC LINE ADAPTER FOR USE WITH 10K-12K DISC BRAKES
9050128	18018-SF	HYDRAULIC HOSE OPTION 90° SWIVEL MALE 3/8"-24 X 3/8"-24 FEMALE 18" LONG
9500067	7828	HYDRAULIC ADAPTER 1/4" FEMALE 3/16" MALE INVERTED FLARE FOR DEXTER ACTUATORS
9500045*	AG-700-AK	LINE KIT - ADD FOR AG-701-TR (ABOVE)



•9500076



•9050128



•9500067



* Add One Of These Kits For Each Additional Axle. I.e., A Triple Would Require One Kit From Above Plus Two Of The Matching Add-On Kits.

DISC		
REF NO	QTY	DESCRIPTION
1	1	3/16" X 72" BRAKE LINE
2	1	3/16" X 30" BRAKE LINE
		3/16" X 5" BRAKE LINE
3	2	13" FLEX BRAKE LINE ML/FML WITH SWIVEL ENDS ON HOSE
4	2	3/16" IF STREET TEE
5	2	HOSE BRKT
6	2	HOSE CLIP
7	2	TUBE CLAMP
8	2	SELF TAB SCREW

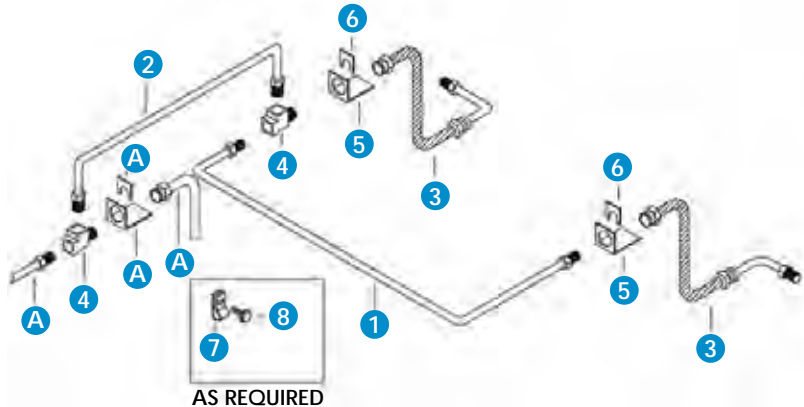

A FOR REFERENCE ONLY. NOT INCLUDED WITH THIS PART NUMBER. **A** REPRESENTS THE SINGLE KIT THAT IS BEING EXTENDED.

HYDRAULIC BRAKE LINE KITS • DISC

HYDRAULIC BRAKE LINE KITS

Designed To Be Used On Trailers With Either Surge Brake Actuators Or Powered Brake Actuators, Such As The Electric Over Hydraulic. Can Be Used With Drum Or Disc Brakes. Brake Lines Are Dot Flexible Hoses Approved For Use On All Trailers. All Fittings Are Brass For Ultimate Corrosion Resistance. Do Not Exceed 3,000 Psi.



ITEM NO	ID NO	DESCRIPTION
9500046	F-100-SA	LINE KIT - SINGLE AXLE "D.O.T. FLEX LINE"

Choose This Line Kit For A Single Axle Drum Or Disc Brake Trailer. For A Tandem, Add-On The Kit Below. I.e., If You Select F-100-Sa, Then For A Tandem Select F-130-Sa Also.

FLEXIBLE • DISC OR DRUM

REF NO	QTY	DESCRIPTION
1	1 EA	72" FLEX BRAKE LINE
2	1 EA	48" FLEX BRAKE LINE
3	1 EA	18" FLEX BRAKE LINE
4	1 EA	3/16" IF UNION TEE W/ BRKT
5	1 EA	3/16" IF ADAPTER TEE
6	3 EA	TUBE CLAMP
7	3 EA	SELF-TAP SCREW
8	3 EA	TIE STRAP

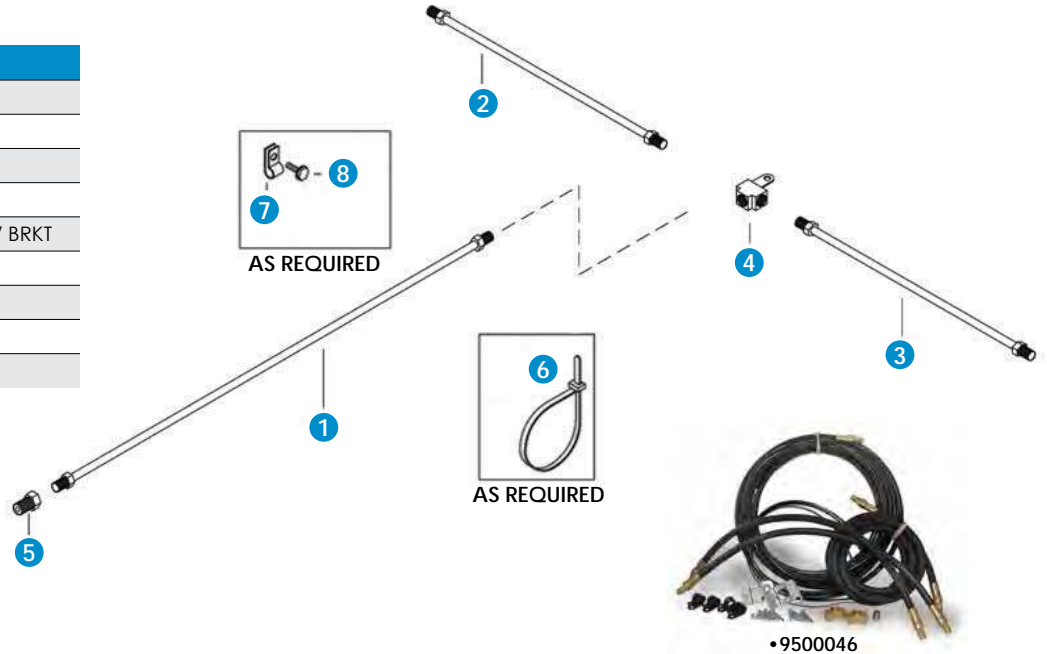

ADD-ON KITS

ITEM NO	ID NO	DESCRIPTION
9500047	F-130-SA	LINE KIT - ADD FOR F-100-SA

* Add One Of These Kits For Each Additional Axle. I.e., A Triple Would Require One Kit From Above Plus Two Of These Add-On Kits.

REF NO.	QTY	DESCRIPTION
1	1	72" FLEX BRAKE LINE
2	1	48" FLEX BRAKE LINE
3	1	18" FLEX BRAKE LINE
4	1	3/16" IF UNION TEE W/ BRKT
5	3	TUBE CLAMP
6	3	SELF-TAP SCREW
7	3	TIE STRAP
8	1	1/8 MPT X 3/16 IF ADAPTER

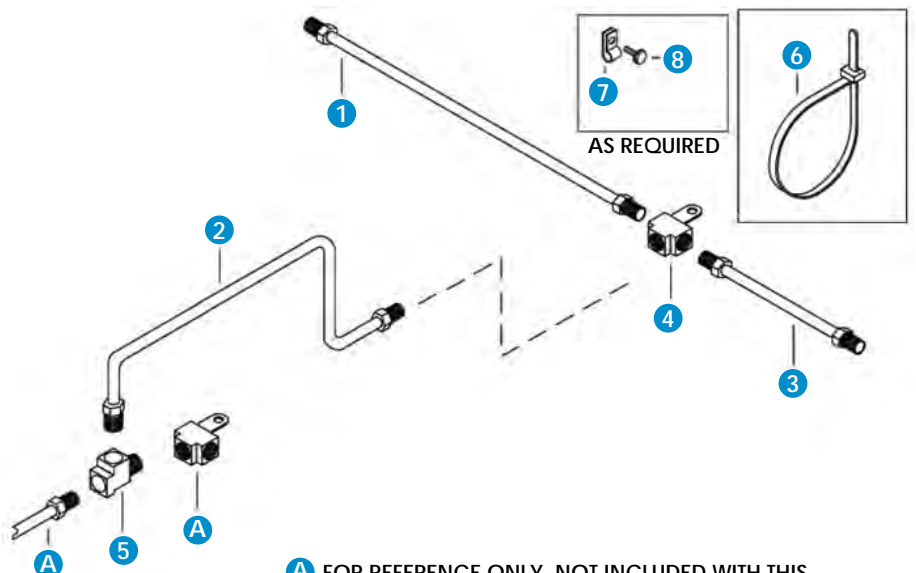

A FOR REFERENCE ONLY. NOT INCLUDED WITH THIS PART NUMBER. **A** REPRESENTS THE SINGLE KIT THAT IS BEING EXTENDED.

HYDRAULIC BRAKE LINE KITS

Designed To Be Used On Longer Trailers. Includes 25 Feet Of Main Line Verses 15 Feet In The Standard Kit. Disc Kit Includes Hoses Designed To Be Used With Disc Brake Calipers With 7/16-20 Male Ends Avoiding The Use Of Additional Fittings.

DRUM		
ITEM NO	ID NO	DESCRIPTION
9500015	T-1002	LINE KIT - TANDEM DUAL DRUM BRAKES

Choose This Line Kit For A Tandem Dual Wheel Drum Brake Trailer.

REF NO	QTY	DESCRIPTION
1	1	3/16" X 25' BRAKE LINE
2	3	3/16" X 51" BRAKE LINE
3	2	3/16" X 60" BRAKE LINE
4	2	18" FLEX BRAKE LINE ML/FML
5	2	HOSE BRKT
6	2	HOSE CLIP
7	2	3/16" IF UNION TEE W/ BRKT
8	1	3/16" IF STREET TEE
9	8	TUBE CLAMP
10	8	SELF-TAP SCREW

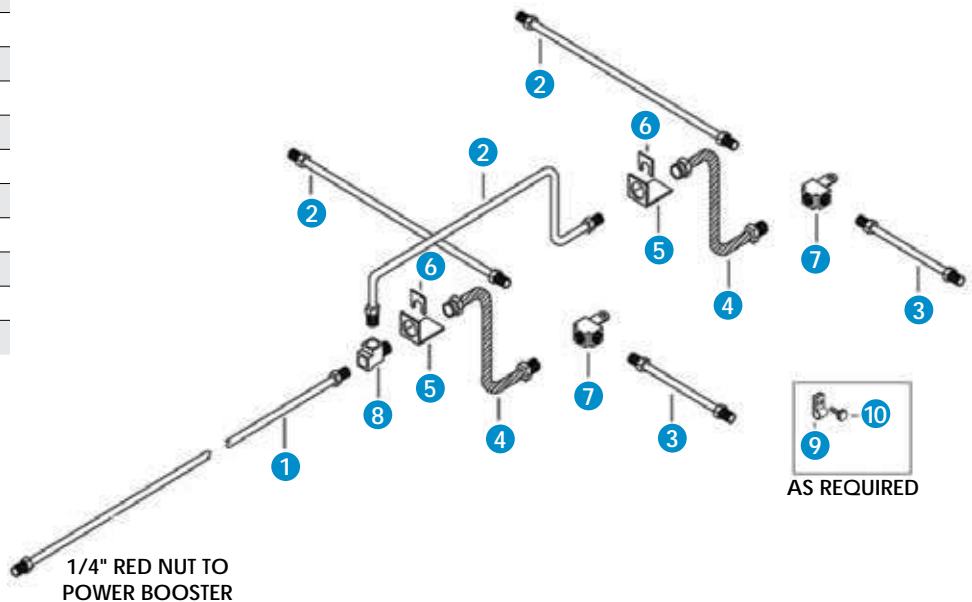

DRUM		
ITEM NO	ID NO	DESCRIPTION
9500014	T-1002D	LINE KIT - TANDEM DUAL DISC BRAKES OR TORFLEX AXLE

Choose This Line Kit For A Tandem Dual Wheel Disc Brake Or Torflex Axle Trailer.

REF NO	QTY	DESCRIPTION
1	1	3/16" X 25' BRAKE LINE
2	1	3/16" X 51" BRAKE LINE
3	2	3/16" X 60" BRAKE LINE
4	4	18" X 7/16-20 FLEX LINE ML/FML
5	4	HOSE BRKT
6	4	HOSE CLIP
7	3	3/16" IF STREET TEE
8	8	TUBE CLAMP
9	8	SELF-TAP SCREW

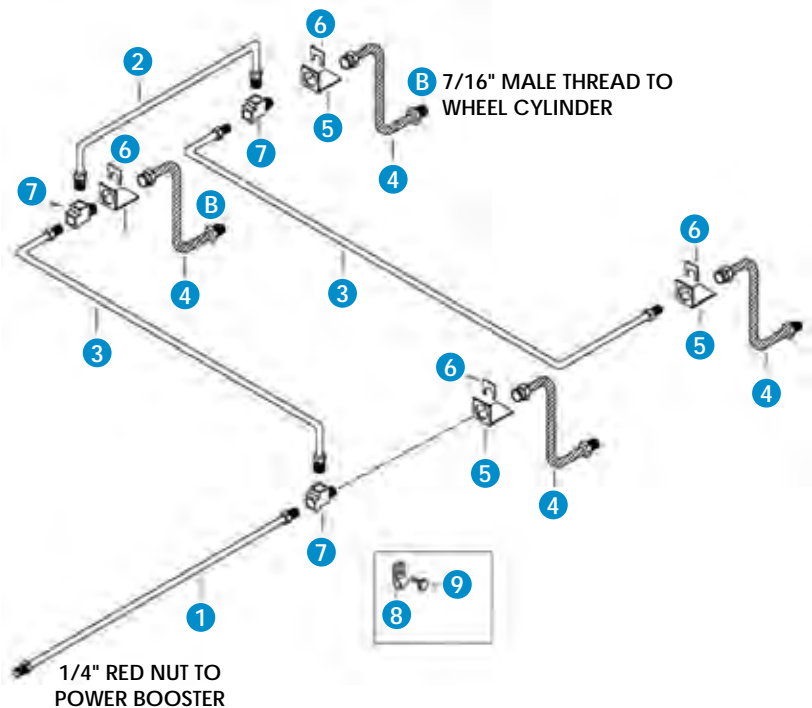

HYDRAULIC BRAKE LINE KITS • FLEXIBLE



TUFF BRAKES.

WHEN PERFORMANCE COUNTS BLUDOT TRAILER BRAKE SYSTEMS DELIVER

Bludot designs and builds the highest quality, pre-packaged trailer brake line systems for manufacturing assembly lines, trailer maintenance and replacement parts. When performance counts, Bludot delivers. And we deliver fast—most of the time within 48 hours.

Order Bludot brake systems ready for the assembly line, pre-designed to your specifications, pre-packaged to your request, and delivered to your facility when you need it. Save time and money consolidating your brake line parts and kits with Bludot brake systems.

From hydraulic brake lines and kits, air/hydraulic, straight air, or flexible line kits, ABS and non-ABS system parts, along with a variety of controllers and components, Bludot is your brake line manufacturing, distribution or replacement source.



PART NUMBER INDEX =

ITEM NO	PAGE(S)	ITEM NO	PAGE(S)	ITEM NO	PAGE(S)
6100673	1	6300082	27	6450755	6
6100894	1	6300191	27	6450760	6
6100895	1	6300314	26	6450765	6
6100931	1	6400028	5	6450810	6
6100932	1	6400029	5	6450835	8
6100933	1	6400085	5	6500012	58
6100934	1	6400086	5	6500017	36
6100935	1	6450182	12	6500027	36
6100936	1	6450392	6	6500051	36
6100937	1	6450393	5	6500064	36
6100938	1	6450394	5	6500075	36
6100939	1	6450406	6	6500106	36
6100940	1	6450414	6	6500140	36
6100941	1	6450415	6	6500141	36
6100942	1	6450503	6	6500146	36
6100943	1	6450504	6	6500152	36
6100944	1	6450505	6	6500153	36
6100945	1	6450510	6	6550003	36
6100946	1	6450511	6	6550010	36
6100948	1	6450563	7	6550011	36
6100949	1	6450565	8	6550016	36
6100951	1	6450579	6	6550019	36
6100961	1	6450580	6	6550020	36
6100962	1	6450581	6	6550021	36
6100963	1	6450586	6	6550028	36 & 58
6100964	1	6450587	6	6550036	36
6100965	1	6450592	7	6550039	36
6100966	1	6450614	7	6550052	36
6100967	1	6450620	6	6700050	28
6100968	1	6450657	6	6700052	28
6100969	1	6450658	6	6700053	28
6100970	1	6450659	6	6700085	8
6100971	1	6450662	6	6700200	28
6100972	1	6450663	6	6700201	28
6250003	35	6450669	6	6700202	28
6250004	35	6450670	6	6700203	28
6250005	35	6450676	6	6750082	43
6250007	36	6450677	6	6750097	23
6250009	35	6450681	6	6750098	23
6250014	35	6450682	6	6750119	23
6251270	36	6450690	6	6750120	23
6300026	27	6450719	7	6750129	45
6300031	27	6450739	8	6750131	24
6300063	27	6450745	6	6750132	24
6300068	27	6450747	6	6750146	50
6300070	27	6450748	6	6750216	24
6300079	27	6450752	6	6750218	24
6300081	27	6450753	6	6750222	24



PART NUMBER INDEX =

ITEM NO	PAGE(S)	ITEM NO	PAGE(S)	ITEM NO	PAGE(S)
6750229	24	7001060	34	7350314	26
6750232	24	7001243	34	7350315	26
6750242	24	7001250-02	34	7350316	27
6750281	23	7001251	34	7350317	27
6750307	43	7001252	34	7350318	27
6750346	24	7001253	34	7350319	27
6750371	24	7010001	56	7350379	26
6750372	24	7010002	56	7350388	26
6750374	24	7010003	57	7350391	26
6750375	24	7010004	58	7350396	27
6750381	24	7010005	58	7350583	26
6750394	24	7010009	56	7350584	26
6750409	24	7010010	56	7350585	26
6750417	24	7010013	54	7350604	27
6750513	24	7010014	54	7350622	25
6750521	24	7010018	57	7350623	25
6750523	24	7010019	57	7350624	25
6750527	24	7030001	24	7350625	25
6750529	24	7030069	12	7350628	25
6750558	24	7030139	12	7350629	25
6750562	24	7030199	12	7350685	26
6750563	24	7030202	12	7350720	28
6900003	35	7030203	12	7351302	26
6900198	35	7030204	12	7351303	26
7000008	34	7050151	16	7351373	27
7000009	34	7050156	16	7351419	26
7000035	35	7050236	16	7351420	26
7000039	34	7050261	16	7351650	26
7000041	35	7050262	16	7351652	26
7000043	35	7050302	16	7351712	27
7000045	35	7050303	16	7351715	27
7000049	35	7050306	16	7351716	27
7000077	34	7050311	16	7351750	26
7000087	34	7050312	16	7351751	26
7000088	35	7050406	16	7351752	26
7000102	34	7050481	16	7351792	26
7000265	34	7050498	16	7351793	26
7000280	34	7350062	26	7351794	26
7000287	34	7350111	27	7600095	22
7000311	34	7350188	26	7600096	22
7000334	35	7350209	26	7600100	22
7000353	34	7350210	26	7600101	22
7000355	34	7350251	26	7600102	22
7000356	34	7350255	26	7600103	22
7000359	34	7350266	26	7600104	22
7000797	35	7350274	27	7600105	22
7000925	35	7350279	26	7600106	22
7000926	35	7350280	26	7600107	22

PART NUMBER INDEX =

ITEM NO	PAGE(S)	ITEM NO	PAGE(S)	ITEM NO	PAGE(S)
7600108	22	7700285	8	8100196	32
7600109	22	7700295	8	8100201	32
7600110	22	7700309	9	8100231	33
7600111	22	7700310	9	8100277	33
7600112	22	7700335	10	8100278	33
7600136	22	7700336	10	8100280	33
7600137	22	7700337	10	8100281	34
7600138	22	7700338	10	8100294	33
7650012-GV	8	7700358	10	8100306	30
7650071-GV3	8	7700359	10	8100359	33
7650071-GV3B	8	7950007	44 & 50	8100363	33
7650073-GV3	8	7950016	23	8100365	31
7650073-GV3B	8	7950075	23	8100366	31
7650077-GV	8	7950096	23	8100367	31
7650083-GV3	8	7950098	14	8100367-02	31
7650085-GV3	8	7950231	23	8100368	31
7650085-GV3B	8	7950232	23	8100369	31
7650272	8	7950235	23	8100372	31
7650273	8	7950243	23	8100373	33
7650344	10	7950244	23	8100375	33
7650347	10	7950247	23	8100376	33
7700004	10	7950248	23	8100379	33
7700005	10	7950266-TT	23	8100384	33
7700008	8	7950314	23	8100386	31
7700016-01	10	7950366	23	8100387	31
7700018-01	10	7950508	23	8100388	31
7700025-01	10	7950512	23	8100389	31
7700036	8	7950515-TT	23	8100390	31
7700037	8	7950518	23	8100397	30
7700044	22	7950539	23	8100398	30
7700045	8	7950561	23	8100403	31
7700048	8	7950574	23	8100404	31
7700053-01	10	7950578	23	8100428	33
7700120	8	8100025	32	8100443	33
7700121	10	8100026	32	8100444	33
7700123	8	8100030	33	8100445	31
7700201	22	8100063	32	8100461	33
7700202	22	8100105	33	8100477	31
7700210	10	8100135	33	8100478	31
7700214	10	8100138	33	8100481	32
7700217	8	8100139	33	8100484	33
7700239	10	8100141	33	8100489	33
7700271	10	8100145	32	8100509	32
7700273	10	8100151	32	8100510	33
7700278	10	8100156	32	8100511	33
7700281	22	8100170	31	8100517	32
7700282	22	8100191	31	8100518	32
7700283	22	8100195	32	8100520	32



PART NUMBER INDEX =

ITEM NO	PAGE(S)	ITEM NO	PAGE(S)	ITEM NO	PAGE(S)
8100532	31	8101540	30	8270004	17
8100565-02	1 & 31	8101553	32	8270005	17
8100565-03	1 & 31	8101554	32	8270006	14
8100593	33	8101565	32	8270007	12
8100600	33	8101566	32	8270008	12
8100601	33	8101581	30	8270009	18
8100625	32	8101582	30	8270010	18
8100626	32	8101598	30	8270011	18
8100627	31	8101600	30	8270012	18
8100627-02	31	8101601	30	8270013	18
8100628	33	8101602	30	8270016	17
8100634	32	8101603	30	8270017	17
8100635	32	8200043	29	8270018	17
8100636	33	8200051	29	8270019	17
8100637	33	8200053	29	8270020	12
8100662	31	8200057	29	8270021	18
8100747	34	8200069	29	8270023	18
8100765	31	8200090	29	8270024	15
8100766	31	8200096	29	8270027	18
8100815	32	8200096-03	29	8270028	18
8100816	32	8200102	29	8270029	18
8100845	32	8200153	29	8270030	18
8100846	34	8200158	29	8270031	18
8100848	33	8200165	29	8270032	18
8100849	33	8200166	29	8270033	18
8100887	33	8200168	29	8270034	12
8100902	32	8200173	29	8270035	12
8100920	33	8200181	29	8270036	14
8100921	33	8200185	29	8270037	14
8100939	30 & 31	8200220	15 & 22	8270038	13
8100960	30	8200316	26	8270039	14
8101035	34	8200350	29	8270040	14
8101082	31	8200354	29	8270041	12
8101083	31	8200362	29	8270042	14
8101141	30	8200367	29	8270043	14
8101174	34	8200408	29	8270044	11
8101177	34	8200412	29	8270045	11
8101178	34	8200430	29	8270046	11
8101179	34	8200440	29	8270047	11
8101203	33	8200484	29	8270048	12
8101230	34	8200485	29	8270049	12
8101347	33	8200702	29	8270050	14
8101377	32	8200705	29	8270051	14
8101378	32	8200770	29	8270052	14
8101404	32	8204311	42	8270053	14
8101405	32	8270001	17	8270054	14
8101436	32	8270002	17	8270055	18
8101515	30	8270003	17	8270057	17

PART NUMBER INDEX =

ITEM NO	PAGE(S)	ITEM NO	PAGE(S)	ITEM NO	PAGE(S)
8270058	18	8550029	25	9000505	12
8270059	18	8550042	25	9000506	12
8270060	18	8550099	25 & 54	9000507	12
8270061	18	8605101	37	9000508	12
8270062	18	8750003	49	9000509	12
8270063	13	8750108	4	9000510	12
8270064	18	8750109	4	9000511	12
8270066	18	8750110	4	9000573	1 & 11
8270067	18	8750111	4	9000583	11
8270072	14	8759132	39	9050008	37
8270073	14	8850025	28	9050009	37
8270084	14	8850029	28	9050013	43
8270085	14	8850031	28	9050017	45
8270086	13	8850032	28	9050019	49
8270087	17	8850128	28	9050020	45
8270103	14	8850137	28	9050029	45
8270104	18	8850138	28	9050031	44 & 50
8270126	18	8850200	27	9050037	45
8270129	14	8900002	15	9050040	45
8270130	13	8900003	15	9050042	45
8270133	17	8900009-01	15	9050046	40
8270154	17	8900010-01	15	9050047	40
8270156	13	8900027	15	9050048	45
8270171	13	8900028	15	9050050	39
8270172	13	8900029	15	9050051	39
8270175	16	8900030	15	9050052	39
8270176	16	8900031	15	9050055	37
8270177	16	9000162	11	9050061	49
8270178	14	9000218	11	9050062	43
8270179	14	9000250	12	9050063	54
8270180	16	9000251	12	9050064	49
8270181	16	9000289	12	9050065	54
8270182	16	9000303	12	9050066	40
8270183	16	9000304	11	9050067	42
8270184	16	9000317	12	9050068	37
8290446	35	9000319	12	9050069	39
8290609	35	9000335	11	9050070	40
8290633	35	9000336	11	9050071	40
8500215	15	9000338	12	9050074	42
8500216	15	9000339	12	9050076	49
8530026	15	9000397	12	9050080	44 & 50
8530028	15	9000403	12	9050081	44
8530033	15	9000496	12	9050082	50
8550001	25	9000500	12	9050083	39
8550011	25	9000501	12	9050085	40
8550013	54	9000502	12	9050089	42
8550024	25	9000503	12	9050091	44
8550026	25	9000504	12	9050092	44



PART NUMBER INDEX =

ITEM NO	PAGE(S)	ITEM NO	PAGE(S)	ITEM NO	PAGE(S)
9050093	43	9050214	38	9300325	19
9050094	43	9050215	46	9400074	19
9050095	49	9050216	39	9400103	19
9050096	49	9050217	39	9400104	19
9050097	54	9050218	46	9400163	19
9050101	50	9050219	46	9400164	19
9050111	39	9050220	46	9400216	19
9050113	43 & 54	9050221	46	9400218	19
9050115	54	9050222	46	9400219	19
9050116	43 & 54	9050223	46	9400221	19
9050117	54	9050224	46	9400226	19
9050122	54	9050225	46	9400253	20
9050123	45	9050226	46	9400256	20
9050124	39	9050227	46	9400270	20
9050125	54	9050228	46	9400312	20
9050126	54	9050229	46	9400315	19
9050127	54	9050230	46	9400318	19
9050132	49	9050231	46	9400326	20
9050133	42	9050232	46	9400328	20
9050138	49	9050234	46	9400334	20
9050140	49	9050235	46	9400340	20
9050141	50	9050241	43	9400342	20
9050142	50	9050245	54	9400352	20
9050144	40	9050246	49 & 54	9400354	20
9050146	49	9050249	43	9400362	19
9050147	37	9050252	40	9400387	19
9050158	42	9050253	39	9400388	20
9050160	39	9050254	41	9400394	19
9050161	37	9050258	37	9400404	19
9050171	44	9050259	37	9400413	20
9050173	46	9050260	38	9400424	19
9050175	38	9050261	38	9400456	20
9050177	37	9050263	41	9400464	20
9050178	43	9100160	11	9400472	20
9050181	40	9100270	1 & 11	9400486	20
9050184	46	9100315	11	9400504	20
9050188	46	9100318	11	9400505	20
9050189	46	9100323	11	9400512	20
9050191	46	9250172	28	9400513	20
9050194	39	9250443	28	9400557	19
9050198	44	9250515	15	9400560	19
9050199	44 & 50	9250563	28	9400576	19
9050203	40	9250613	28	9400589	19
9050206	38	9250614	28	9400600	20
9050207	46	9300041	19	9400601	20
9050208	46	9300314	19	9400609	20
9050209	46	9300315	19	9400639	21
9050213	37	9300319	19	9400640	21

PART NUMBER INDEX =

ITEM NO	PAGE(S)	ITEM NO	PAGE(S)	ITEM NO	PAGE(S)
9400642	19	9500076	61	9900077	34
9400661	21	9500084	59	9900086	34
9400667	21	9500085	59	9900090	35
9400674	21	9500086	59	9900145	34
9400676	21	9500087	59	9900179	34
9400677	21	9500089	59	9900180	34
9400678	21	9500090	59	9900311	34
9400682	21	9500091	59	9900312	34
9400683	21	9500092	59	9900356	32
9400687	21	9500093	59		
9400688	21	9500094	59		
9400689	21	9500095	59		
9400691	21	9500096	59		
9400692	21	9500097	59		
9400693	21	9500098	59		
9400694	21	9500099	59		
9400706	21	9500100	59		
9400707	21	9500101	59		
9400708	21	9500102	59		
9400709	21	9500128	61		
9400710	21	9700376	18		
9400712	21	9700377	18		
9400726	21	9700378	18		
9400733	21	9700379	18		
9400734	21	9700380	18		
9400739	19	9700411	18		
9400740	21	9850018	25		
9400742	21	9850073	25		
9400743	21	9850074	25		
9400747	20	9850075	25		
9400763	20	9850076	25		
9400771	19	9850083	15		
9400949	21	9850084	15		
9400950	21	9850085	15		
9400956	21	9850089	15		
9450115	28	9850095	25		
9450419	28	9850102	25		
9500014	63	9850111	25		
9500015	63	9850146	25		
9500038	60	9850167	25		
9500039	60	9850168	25		
9500040	60	9850169	25		
9500041	60	9850178	25		
9500044	61	9850179	25		
9500045	61	9850236	1		
9500046	62	9850237	1		
9500047	62	9900055	34		
9500067	56, 58 &	9900071	34		

NOTES: (Record Catalog Changes Reported for a quick reference).



INDEX =

4-Way Electrical Connections	34 - 35	Brake Line Kit Hydraulic Stainless Steel - Sprung Add-On to Single Axle (Tandem & Triple) Disc Brake.....	61
5-Way Electrical Connections	34	Brake Line Kit Hydraulic Stainless Steel - Sprung Add-On to Single Axle (Tandem & Triple) Drum Brake	60
6-Way Electrical Connections	34	Brake Line Kit Hydraulic Stainless Steel - Sprung Single Axle Disc Brake.....	61
7-Way Electrical Connections	34 - 35	Brake Line Kit Hydraulic Stainless Steel - Sprung Single Axle Drum Brake.....	60
Actuator Diagrams	43 - 55	Brake Line Kit Hydraulic Stainless Steel - Torsion Add-On to Single Torsion Axle (Tandem & Triple).....	61
Actuator, Brake	37 - 42	Brake Line Kit Hydraulic Stainless Steel - Torsion Single Axle	61
Adapter, Brake Controllers.....	36	Brake Line Kit Hydraulic Steel 25' - Sprung Tandem Dual Disc Brake	63
Adapter, Electrical.....	35	Brake Line Kit Hydraulic Steel 25' - Sprung Tandem Dual Drum Brake.....	63
Adjustable Ball Mount Assemblies.....	26	Brake Line Kit Hydraulic Steel 25' - Torsion Tandem Dual Drum or Disc Brake.....	63
Aluminum Adjustable Ball Mount Assemblies	26	Brake Line Kit Hydraulic Steel Line- Sprung Add-On to Single Axle (Tandem & Triple) Disc Brake.....	61
Aluminum Ball Mount Assemblies 25		Brake Line Kit Hydraulic Steel Line- Sprung Add-On to Single Axle (Tandem & Triple) Drum Brake	60
Aluminum Cargo Carrier	27	Brake Line Kit Hydraulic Steel Line- Sprung Single Axle Disc Brake	61
Aluminum Locks	29	Brake Line Kit Hydraulic Steel Line- Sprung Single Axle Drum Brake... 60	
Aluminum Tongue Box.....	28	Brake Line Kit Hydraulic Steel Line- Torsion Add-On to Single Torsion Axle (Tandem & Triple).....	61
Aluminum Wheel & Tire Assemblies.....	20	Brake Line Kit Hydraulic Steel Line- Torsion Single Axle	61
Aluminum Wheels.....	19	Brake Line Kits, Hydraulic	60 - 63
Axle - #10 Torsion Suspension Axle	2	Breakaway Charger Replacement Pins.....	36
Axle - #11 Torsion Suspension Axle	3	Breakaway Chargers.....	36
Axle - #12 Torsion Suspension Axle	3	Breakaway Kits	36
Axle - #9 Torsion Suspension Axle	2	Bunk Brackets.....	14
Axle - D22 Round Tube Spring Axle	2	Bunk Carpet.....	14
Axle - D35 Round Tube Spring Axle	2	Bunk Covers	17
Axle - D52 Round Tube Spring Axle	3	Bunk Slides.....	17
Axle - D60 Round Tube Spring Axle	3	Bunk Wraps	17
Axle - D70 Round Tube Spring Axle	3	Bunkboard Guide-Ons.....	13
Axle - M22 Square Tube Spring Axle	1 - 2	Cable Locks	29
Axle - M35 Square Tube Spring Axle	1 - 2	Cable Ties.....	34
Axle - Square Tube Axle Trailer Quick Reference Buying Guide.....	1	Cable, Battery	35
Axle Seats (Saddles)	11	Caps	15
Backup Assist - Hitchin Rods.....	27	Cargo Carrier.....	27
Backup Lights.....	33	Caulk	28
Ball - Towing	27	Center Caps	22
Ball Mount Assemblies	25 - 26	Chain, Safety	28
Battery	35 - 36	Channel Bracket	24
Battery Box	35	Chargers, Solar / Electrical.....	35
Battery Cables.....	35	Chrome Adjustable Ball Mount Assemblies	26
Battery Chargers	35 - 36	Cleaners	28
Blue Tooth SMART Padlocks	29	Clearance / Marker Lights	32 - 33
Boat Rollers.....	18	Combination Hitch Ball Assemblies.....	25
Bolster Brackets.....	12	Conspicuity Tape	30
Bolt Vehicle Specific Locks.....	29	Coupler Accessories.....	23
Bow Tie Downs.....	28	Coupler Handle Locks	29
Box, Battery	35		
Box, Tongue	28		
Brake - Hydraulic Disc.....	6 - 7		
Brake - Hydraulic Drum.....	5		
Brake Actuator	37 - 42		
Brake Actuator Parts Diagrams	43 - 55		
Brake Control Adapters.....	36		
Brake Controls	36 & 58		
Brake Hoses, Hydraulic	59		
Brake Line Kit Hydraulic Rubber Flex - Sprung Single Axle Drum or Disc Brake	62		
Brake Line Kit Hydraulic Rubber Flex - Sprung Add-On to Single Axle (Tandem & Triple) Drum or Disc Brake	62		

INDEX =

Coupler Locks.....	29	Hydraulic Steel Line Kit - Sprung Add-On to Single Axle (Tandem & Triple) Disc Brake	61
Couplers.....	24	Hydraulic Steel Line Kit - Sprung Add-On to Single Axle (Tandem & Triple) Drum Brake	60
DAP.....	28	Hydraulic Steel Line Kit - Sprung Single Axle Disc Brake.....	61
Door Locks.....	29	Hydraulic Steel Line Kit - Sprung Single Axle Drum Brake	60
Double Ball Mount Assemblies.....	26	Hydraulic Steel Line Kit - Torsion Add-On to Single Torsion Axle (Tandem & Triple).....	61
Electric Over Hydraulic Actuator Kits.....	56 - 58	Hydraulic Steel Line Kit - Torsion Single Axle	61
Electrical Adapters.....	35	Hydraulic Steel Line Kit 25' - Sprung Tandem Dual Disc Brake.....	63
Electrical Connection Tester.....	34	Hydraulic Steel Line Kit 25' - Sprung Tandem Dual Drum Brake	63
Electrical Connections	34 - 35	Hydraulic Steel Line Kit 25' - Torsion Tandem Dual Drum or Disc Brake.....	63
Electrical Tape.....	34	I-Beam Guide-On Brackets.....	13
Fender Mounting Bracket	16	Jack Accessories.....	23
Fender Step Pads.....	16	Jacks.....	23
Fenders.....	16	Keel Pads.....	18
Five Way Electrical Connections.....	34	Keel Roller Brackets.....	14
Fold-Away Coupler Hinge.....	24	King Pin Lock.....	29
Four Way Electrical Connections.....	34 - 35	LED Clearance / Marker Lights	32 - 33
Galvanize Spray Coating.....	15	LED Light Bars.....	33 - 34
Galvanized Wheel & Tire Assemblies.....	19	LED Lighting.....	30 - 32
GloLight® LED Lighting.....	30	License Plate Holders.....	33
Gooseneck Locks.....	29	Light Bars	33
GPS Equipment Tracker.....	35	Light Bracket for Stud Mount Lights.....	34
Grease.....	8	Light Kits.....	30 - 32
Grease Caps	10	Line Kits, Hydraulic.....	60 - 63
Guide-On Brackets	13	Locking Lug Nuts	15
Guide-On Light Kits	30	Logo Reflective Tape.....	30
Guide-On Mounting Brackets.....	13	Manual Crank Winch.....	25
Guide-On Post.....	13	Mirror - Towing	27
Gunwale Tie Downs.....	28	Mobile Supported - Web Based GPS Tracker	35
Hangers.....	11	Mult-Ball Mount Assemblies.....	26
Hardware Kit for Coupler Mount	24	Nut, Locking Lug.....	15
Harnesses, Brake Controllers.....	36	Padlock	29
Harnesses, Trailer Light Wiring.....	34	Paint - Galvanize Spray Coating.....	15
Hinge, Fold-Away Coupler.....	24	Painted Couplers	24
Hitch Balls.....	27	PAL Nuts.....	14
Hitchin Rods - Backup Assist.....	27	Pintle Eyes / Hooks.....	25
Hose Kits Hydraulic	60 - 63	Pintle Lock.....	29
Hose, Hydraulic.....	59	Pipe Add-On Light Kits.....	30
Hub - Drum Bearing Buddy	10	Pipe Light Kits.....	30
Hub - Drum Kits	8	Polishers.....	28
Hub - Drum Lubrication Kits.....	9 - 10	Poly Tongue Box.....	28
Hydraulic Hoses.....	59	Pontoon V-Brackets.....	14
Hydraulic Rubber Flex Line Kit - Sprung Add-On to Single Axle (Tandem & Triple) Drum or Disc Brake.....	62	PVD Chrome Steel Wheel & Tire Assemblies.....	21
Hydraulic Rubber Flex Line Kit - Sprung Single Axle Drum or Disc Brake.....	62	Pyramid Washers.....	14
Hydraulic Stainless Steel Line Kit - Sprung Add-On to Single Axle (Tandem & Triple) Disc Brake	61	Ratchet Straps.....	28
Hydraulic Stainless Steel Line Kit - Sprung Add-On to Single Axle (Tandem & Triple) Drum Brake	60	Receiver Adapter Sleeve.....	27
Hydraulic Stainless Steel Line Kit - Sprung Single Axle Disc Brake	61	Receiver Hitch Pins.....	26
Hydraulic Stainless Steel Line Kit - Sprung Single Axle Drum Brake	60	Receiver Lock Set.....	26 & 29
Hydraulic Stainless Steel Line Kit - Torsion Add-On to Single Torsion Axle (Tandem & Triple).....	61	Receiver Locks.....	26 & 29
Hydraulic Stainless Steel Line Kit - Torsion Single Axle.....	61	Receiver Tubes	27
		Remover, Black Streak.....	28
		Roller Brackets	14



INDEX =

Roller Shafts.....	14
Rubber Flex Hoses.....	59
Safety Chain.....	28
Sealant.....	28
Seals.....	10
Seven Way Electrical Connections.....	34 - 35
Shackle Bolt & Nut.....	11
Shackle Straps.....	11
Silicone.....	28
Single Speed Winch.....	25
Six Way Electrical Connections.....	34
Solar Charger / Maintainer.....	35
Spare Tire Mount.....	15
Spindle - Removable Torsion Suspension Spindle Kit.....	4
Spindle Seal Kits.....	10
Split Roller Brackets.....	14
Stainless Steel Braided Hydraulic Hose Lines.....	59
Straps, Ratchet.....	28
Stud Mount Light Bracket.....	34
Submersible Stop, Tail & Turn Lights.....	30 - 32
Sway Control & Weight Distribution Hitch.....	27
Tape, Electrical.....	34
Tape, Reflective Conspicuity.....	30
Tester, Electrical Connection.....	34
Tie Plates.....	11
Tire Only.....	19
Tongue Box.....	28
Towing Mirror.....	27
Tracker, Equipment GPS.....	35
Trailer Wire Tester.....	34
Transom Ratchet.....	28
Triple Ball Mount Assemblies.....	26
Tube Caps.....	15
Two-Speed Winch.....	25
U-Bolt Double Brackets.....	12
U-Bolt Hardware.....	12
U-Bolt Kits.....	11
U-Bolts.....	12
Utility Light Bars.....	34
V-Bar Guide-On Brackets.....	13
V-Brackets.....	14
Waterproof Stop, Tail & Turn Lights.....	30 - 32
Web Based - Mobile Supported GPS Tracker.....	35
Weight Distribution & Sway Control Hitch.....	27
Wheel Bolts.....	8
Wheel Center Caps.....	22
Wheel Locks.....	29
Wheel Nuts.....	8 & 22
Wheel Studs.....	8
Winch Post.....	15
Winch Straps.....	25
Winches.....	25
Zinc Plated Couplers.....	24
Zip Line, Breakaway Charger.....	36
Zip Ties.....	34



Cargo Strap Protector

Part# 9250627



Use where straps make contact with your cargo or trailer to keep your straps from wearing down!



NO More Broken Straps!

AMERICA'S FASTEST GROWING TRAILER PARTS DISTRIBUTOR!

www.TexTrail.com | 844-TexTrail

AD



1-844-TexTrail



REPLACEMENT PARTS

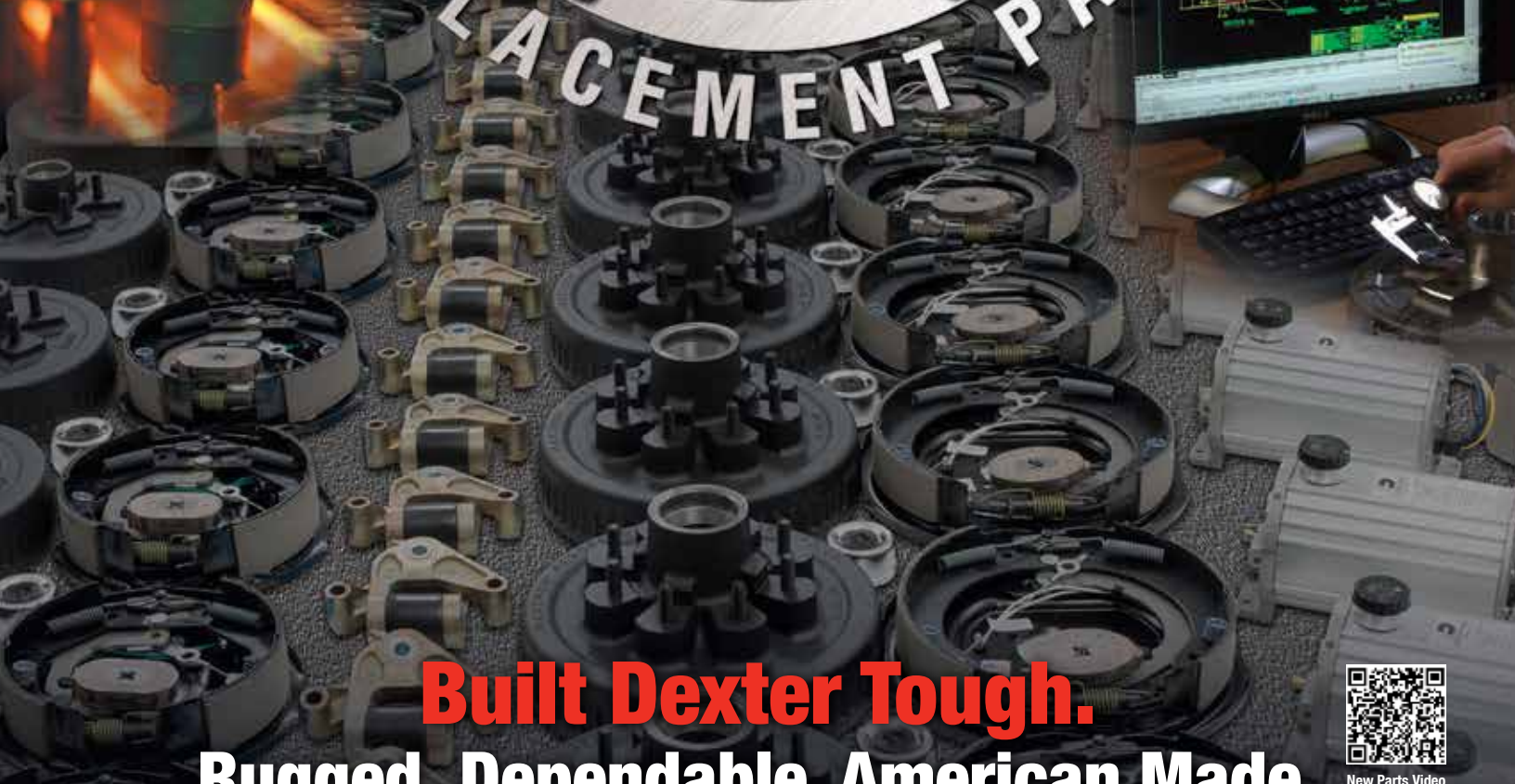

Built Dexter Tough.

Rugged. Dependable. American Made.

Available nationwide with the industry's best two year warranty.

Contact us today: (574) 295-7888 ■ www.dexteraxle.com ■ 2900 Industrial Parkway East ■ Elkhart, IN 46516



New Parts Video



LARGEST EXCLUSIVE DEXTER AXLE DISTRIBUTOR IN AMERICA